



REQUEST FOR INFORMATION

**PROPOSED ESTABLISHMENT OF A POWER AND CHILLED WATER PLANT
IN A DATA CENTRE PARK IN SINGAPORE**

IDA (RFI)-028

ISSUED ON 11 MAY 2011

Table of Contents

INTRODUCTION	3
OBJECTIVES OF RFI	4
SUBMISSION OF INFORMATION	5
CONFIDENTIALITY OF INFORMATION	5
DISCLAIMERS	5
VARIATION	6
FORMAT OF SUBMISSION	6
CLOSING DATE OF SUBMISSION	7
ENQUIRIES	7
ANNEX A: BACKGROUND of DCP	8
ANNEX B: LOCATION PLAN FOR DCP	11
ANNEX C: OVERVIEW ON PROVISIONING OF POWER/CHILLED WATER ...	12
ANNEX D: SCOPE OF RFI	14
ANNEX E: GUIDELINES FOR SUBMISSION OF RFI	20

REQUEST FOR INFORMATION (RFI)

Proposed Establishment of a Power and Chilled Water Plant in a Data Centre Park in Singapore

INTRODUCTION

1. The Info-communications Development Authority of Singapore (“IDA”) is leading a multi-agency initiative in development of a Data Centre Park (“DCP”), which is a specialised industrial park for data centres (DC) with infrastructure, facilities and design guidelines supportive of the setup of premium DCs¹. The key stakeholders supporting this initiative include JTC Corporation (“JTC”) and Economic Development Board (“EDB”).
2. As of November 2010, there was a total of 222,829 sqm of DC space in Singapore. Total DC capacity in Singapore, Malaysia, Thailand and Indonesia is also expected to increase 61.4% in the next five years, from 368,920 sqm in 2010, to 595,371 sqm in 2015. Table 1 shows the breakdown of DC space capacities in the 4 countries:

Country	Capacity (sqm)
Singapore	222,829
Malaysia	108,401
Thailand	19,646
Indonesia	18,044

Table 1²: DC space capacities for Singapore, Malaysia, Thailand and Indonesia

3. The development of a DCP in Singapore will strengthen Singapore’s position as an economic hub by attracting MNCs and enterprises to set up their premium DC operations here. It will also help to entrench Singapore as an infocomm and media hub by having more premium DCs such as banks and telco carriers located here. Such DC infrastructure will attract world-class Internet and media companies to host their content and services in Singapore, thus attracting more Internet traffic and international network providers. Ultimately, this will enhance Singapore’s global connectivity and competitiveness.
4. Power and cooling are crucial to the operations of the DCs. Thus, one of the DCP’s key value propositions is to have an onsite integrated power and chilled water plant (“the Plant”) which increases the overall energy efficiency of the DCP. The Plant will provide reliable power supply with minimal transmission losses and can provide a primary source for chilled

¹ Premium DCs are defined as DCs with dual feeds for its utilities such as power and chilled water, multiple telecoms connectivity options and redundant designs in its infrastructure components. In industry terms, it is commonly classified as Tier 3 and above DCs according to the technical standards set out by the Uptime Institute (an association for the DC industry and often used as an industry reference). Please refer www.uptimeinstitute.org/ for more information.

² Source: BroadGroup Report - “Data Centres South East Asia” (Nov 2010)

water for the tenants within the park. By leveraging the economics of scale of the shared cooling facilities, better efficiency is achieved and energy costs can be potentially lowered. In addition, while existing DCs require in-building space to house their chilled water equipment, the shared chilled water facilities in the DCP can allow DCs to free up this space for more revenue-generating activities.

5. Recent analyst reports³ indicated that the power demand for Data Centres have grown significantly and there has been bigger spending on DC operational costs to provision for more power and cooling for their customers. The provision of the Plant in DCP will provide an excellent revenue opportunity for power and cooling players, riding on the growth in DC industry.
6. Given the significance of the Plant to DCP, the appointed power and chilled water plant developer (“Plant Developer”) will be an important partner to this government-led initiative. The successful implementation of this large scale national project can provide an excellent testimony and reference for the appointed Plant Developer.
7. As this project is a first of its kind in the world, the appointed Plant Developer will have a good opportunity to be part of a Proof-Of-Concept platform for the future DC environment. This also gives the Plant Developer the perfect test-bed to try out the latest power and cooling technology. A successful roll-out of DCP in Singapore can also provide opportunities for the appointed Plant Developer to export or replicate the concept into other overseas markets.

OBJECTIVES OF RFI

8. The aim of this RFI is to gather information for which the Plant can be best developed for DCP. **Annex A: Background of DCP** and **Annex C: Overview on Provisioning of Power/Chilled Water** provides the background information for the RFI.
9. IDA will like to invite prospective companies to submit information (as outlined in **Annex D: Scope of RFI**) relevant for developing onsite power/chilled water infrastructure for DCP.
10. In conceptualising the Plant, IDA will like respondents to specifically address the following issues regarding:
 - a) Technical specifications to fulfil plant requirements,
 - b) Regulatory requirements, and
 - c) Commercial considerations in fulfilling plant requirements

³ Source: IDC report – Innovations for the Future Virtualized Data Centre (Oct 2009) and Gartner report – How to Measure Energy Consumption in Your Data Centre (Sept 2010)

11. IDA intends to use the responses to the RFI to draw up detailed specifications, operating and business terms in the RFP for the DCP. As a result of the RFI, IDA may:
 - a) Engage in further discussions and negotiations with the organisation;
and
 - b) Proceed to issue an open call for Request for Proposals (RFP).
12. Prospective companies are also welcomed to provide additional proprietary or general information beyond Annex D for e.g. specific terms and conditions for the power/chilled water provisioning, which is relevant and useful for RFP.

SUBMISSION OF INFORMATION

13. This RFI is a mechanism for gathering information for the power/chilled water infrastructure for DCP. It does not constitute a procurement.
14. Respondents are invited to submit proposals for provision of power/chilled water in accordance to **Annex E: Guidelines for submission of RFI.** Respondents can either submit proposals for entire scope or a selection of individual segments as listed in **Annex D: Scope of RFI.**

CONFIDENTIALITY OF INFORMATION

15. IDA encourages submission of original ideas and will respect confidentiality on proprietary and commercially sensitive information. Companies are to state which parts of the information are proprietary or commercially sensitive information.
16. However, there may be instances where the ideas or information is already residing with the IDA, EDB and JTC, overlap with ideas or information submitted by other companies, or are already available in the public domain. In such cases, the ideas will not be considered as proprietary and the IDA, EDB and JTC reserves the right to use them.

DISCLAIMERS

17. This RFI is merely an invitation to treat and is not intended to create or impose any binding legal obligations whatsoever on IDA, whether express or implied and whether contractual or otherwise. Without prejudice to the generality of the foregoing, each company acknowledges and agrees that IDA shall be under no duty or obligation to act fairly or equally towards the company in relation to IDA's evaluation of its proposal or with regard to any process adopted by IDA under this RFI.
18. Nothing in the RFI shall constitute a contract between IDA and any company submitting a proposal or information.

19. All submissions of proposals or information relating to this RFI shall be made entirely at the risk of the company.
20. IDA does not make any representation or warranty, whether express or implied, or accept any liability for the completeness, relevancy, accuracy and/or adequacy of the information provided by IDA in this RFI.
21. IDA accepts no liability of obligation in relation to any proposal or information submitted pursuant to this RFI. Each company shall bear all costs and expenses associated with the preparation and submission of its proposal or information.
22. The receipt by IDA of any proposal pursuant to this RFI shall under no circumstances impose any form of obligation or amount to an acceptance of or an agreement to abide by any terms or conditions stated therein on the part of IDA.
23. IDA shall have the absolute discretion, at any time, to terminate this RFI or to change the nature, scope, procedures or timelines for the RFI. Under no circumstances shall IDA incur any liability in respect of such termination or changes.
24. IDA shall not owe any liability to any party for any loss or damage whatsoever (including loss of profit, savings, business contracts, or revenues, and all other forms of actual, direct, special, incidental, or consequential loss or damage) arising from or related to any response to this RFI, including but not limited to the submission of proposals or information.

VARIATION

25. IDA reserves the right to update and/ or modify content contained within the **Annex D: Scope of RFI**. Such updates and modifications may be issued as *Corrigendum*.

FORMAT OF SUBMISSION

26. Information must be submitted in English and written in a clear and concise manner.
27. The submission shall be typed single-spacing with Arial font size 12. Please leave space for margin of 2.5cm on the left and right, top and bottom.
28. Submissions should be made in hard copy (4 sets) and soft copy (1 set) in Word format.

29. The submission shall contain the following details:
- a) Name of Company or Consortium
 - b) Company Address
 - c) Nature of Business
 - d) Contact Person(s)
 - e) Designation(s)
 - f) Designated Email(s)
 - g) Contact Number (s)
 - h) Facsimile Number (s)
30. Please submit soft copies via email to: IDA_DCP@IDA.GOV.SG. For hard copy submissions, please address them to:

Infocomm Development Authority of Singapore
10 Pasir Panjang Road
#10-01 Mapletree Business City
Singapore 117438
Attention: Ms Chwee Jyh Woan
Subject: Request for Information – Proposed Establishment of a Power and Chilled Water Plant in a DCP in Singapore

CLOSING DATE OF SUBMISSION

31. The closing date of the submission is **8 June, 2011** at **1400hrs**. Please send all submissions to IDA_DCP@ida.gov.sg prior to the closing date.

ENQUIRIES

32. All enquiries regarding this request shall be sent to IDA_DCP@ida.gov.sg.

ANNEX A: BACKGROUND of DCP

1. In today's digital age, financial institutions, telecommunication companies, computer gaming companies, internet search firms, software development companies and logistics and manufacturing enterprises rely heavily on infocomm for their business processes and operations. DC infrastructure has become a critical component for these business operations. In order to attract these enterprises and strengthen Singapore as a knowledge-based economy, Singapore needs to have extensive and reliable DC infrastructure.
2. In addition, many local DC players are actively looking to expand as their current facilities are unable to satisfy the growing DC requirements. With the demand for more computing, power requirements have been rising very quickly. This is a result of the adoption of blade servers to maximise rack space and virtualisation to allow servers to take on more computing load. Thus, many DC players face the challenge of inadequate power and chilled water infrastructure at their existing facilities.
3. According to analyst reports⁴, it is estimated that nearly two percent of the world's power supply is spent powering data centres. The demand for power is expected to grow as there is a bigger need for high power computing arising from the growing adoption of virtualization and cloud computing. It was also captured from these reports that the worldwide spending on Data Centre operations, especially for power and cooling, has seen a significant increase since 2005.
4. There is also a noticeable trend of growing demand by premium DC end users such as financial institutions which typically require DC space with high standards to meet their stringent regulatory or service requirements. This demand for premium DC space is driven by lack of existing DC spaces which are able to meet the high end data centre requirement in terms of infrastructure, service quality and operating efficiency.
5. In Singapore today, DCs are built in many different locations as DC players are dependent on where and when plots of land are available. Much time is needed to prepare land due to stringent DC requirements, secure connection to two substations with generator sets as back up and telecoms connectivity to their premises, and resolve outstanding government guidelines and issues for power, water and connectivity. Thus current DC development in Singapore is not optimal to sustain long-term growth of DC industry. With limited resources, setting aside land dedicated to DCs will prove to be attractive to companies as it provides an easier, faster, efficient and central approach to setting up DCs in Singapore.

⁴ Analysts from IDC and Gartner state that two percent of total energy consumed worldwide is caused by data centres. This share is expected to double within the next five years. Data Centre energy costs have climbed to represent more than 20% of the total operation expenses in most companies. In the short- and mid-term, this share will increase to more than 30%.

6. IDA believes that DCs can be clustered together efficiently in a DCP for the following reasons:
 - a) Economies of scale – power and chilled water infrastructure can be shared between DCs for greater power and chilled water efficiency and potential cost savings.
 - b) Efficient use of land – industrial guidelines such as plot ratio, aesthetic requirements and carpark space can be customised for the DCP to yield higher gross floor area and net usable DC space.
 - c) Ease of connectivity – clustering DCs near a node of a neutral Internet Exchange (IX) will allow DCs to connect to the IX with minimal physical infrastructure.
7. The DCP will therefore bring about cost savings, faster time to market for DC operators and hence make Singapore a more attractive location for DC investors, content providers and international carriers.



Figure 1: Conceptual Diagram of the proposed DCP⁵

8. The proposed DCP, which is targeted to be completed by 2013-2014, is estimated to occupy an area of 13 Ha and can consist of approximately six to eight DC buildings providing at least 74,000 m², up to 111,000 m² of net lettable area (NLA). Investors will have a selection of various land plots to enable them to rapidly build their own DC facility within the DCP, leveraging various supporting infrastructure to get to market quickly and reduce overall capital expenditure and operating costs. The proposed site is at Tanjong

⁵ Artist's impression; not representative of actual site layout.

Kling and the Plant would be sited in the shaded region (refer to Annex B). However the site serves only as a guide for the RFI, by no means does this necessarily constitute to an actual site being considered. IDA and JTC reserve all rights on the site selection for the DCP project.

9. The following are the key features of the DCP:
 - a) Redundancy and resiliency in infrastructure – As DCs are mission-critical facilities; infrastructure in the DCP will be designed to support fully redundant and resilient configuration. For example, DCP will support dual power feeds, redundant sources of chilled water and network path diversity to ensure that DC operations will not be compromised if any part of the infrastructure should fail.
 - b) Ready-built infrastructure – Supporting infrastructure will be available and easily scalable for plug-and-play DC deployment. A purpose-built on-site power and chilled water plant will be built to meet the high chilled water requirements of next-generation DCs and ensure the reliable supply of power with minimal transmission losses. The shared chilled water facilities will result in better energy efficiency, lower costs and less space needed to house chilled water equipment, which DCs will typically buy separate chilled water equipment in their building. Telecommunication infrastructure such as high capacity fibre networks and Internet exchange will also be established for the connectivity needs of DCs.
 - c) Ready DC plots and customised industrial park guidelines – Plots of land will be demarcated within the DCP and made available at competitive pricing for DC investments. Existing industrial guidelines can also be reviewed where necessary, with recommendations to match the specific requirements of DCs. Issues such as guidelines for building design, aesthetics, plot ratio and carparks are areas where DCs have more specific requirements.
10. The operating environment of the DCs in DCP will be similar to that of a typical DC. Typical ambient air temperature for a DC is 22 degree Celsius, with an allowable range of ± 2 degree Celsius. Required relative humidity is 50%, with a range of $\pm 5\%$. High end DCs also require at least N+2 redundancy for critical equipment and usually have ultimate load requirement of 20 to 30MW per building.

ANNEX B: LOCATION PLAN FOR DCP

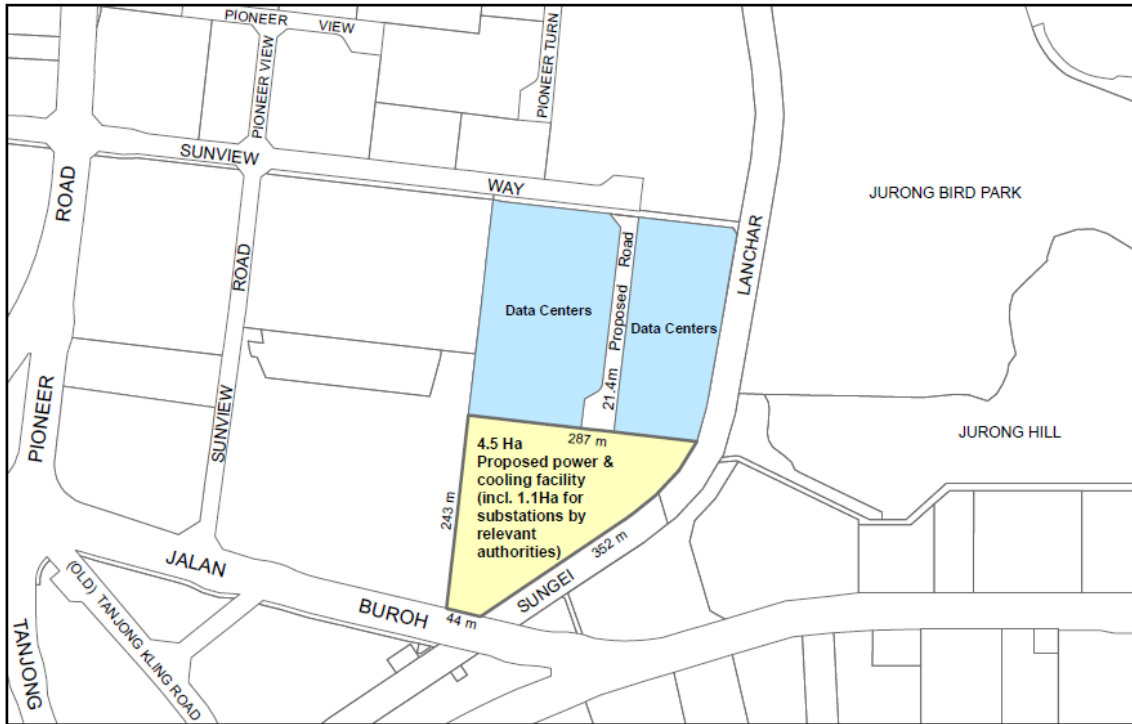

JTC Corporation
LAND PLANNING DIVISION

LOCATION PLAN

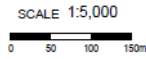

PLAN NO: JTC/11/JRW57
DATE: 09 05 2011
PREPARED BY: ANNIE LIM

ANNEX C: OVERVIEW ON PROVISIONING OF POWER/CHILLED WATER

1. The provision of common purpose built infrastructures is a key differentiating factor which will make DCP more attractive to potential investors. The Plant has been identified as one of the key common purpose built infrastructure for DCP.
2. Chilled water will be directly supplied from the Plant to the end users in DCP. For provision of power supply, end users in DCP must buy the power from electricity retailers and their installation (DC building) must be connected to the power grid network to obtain power supply as their main or back-up source. The Plant will also have to be connected to the power grid network in accordance with the Transmission Code issued by EMA. The Plant Developer also must participate in the National Electricity Market of Singapore (NEMS) in accordance with the prevailing Market Rules. The sources of power and chilled water will support full redundancy required to meet the highest stringent requirements of DCs for scaling purposes.
3. The Plant Developer is expected to develop and own the Plant, including the chilled water reticulation pipes.
4. The Plant is to operate at least 30 years, and the Plant Developer is to undertake the design, construction and operation of the service corridors to house the distribution infrastructure for chilled water.
5. The Plant Developer may independently construct the Plant on the leased land parcels or may subcontract a constructor to do so.
6. The Plant Developer may also independently operate the Plant and its facilities or may sub-contract an operator to do so.
7. The Plant Developer can either sell chilled water alone to the end users in DCP (Figure 2) or work with a retailer to bundle both power and chilled water to sell to end users in DCP (Figure 3). For both scenarios, the Plant Developer has to participate in the NEMS and sells the generated power in the wholesale market.

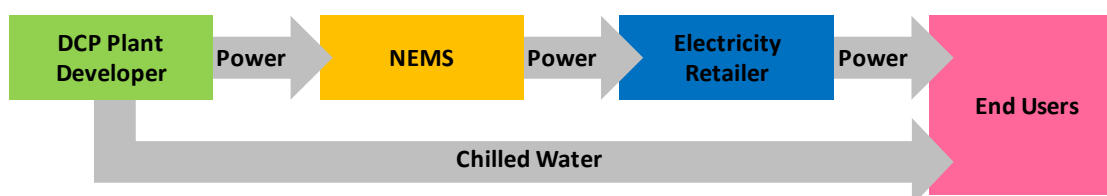

Figure 2: Plant Developer sells only chilled water to end users in DCP

Request for Information
Proposed establishment of a power
and chilled water plant in a DCP in Singapore

11 May 2011

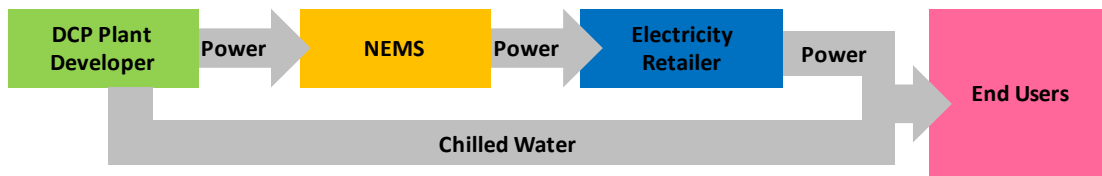

Figure 3: Plant Developer works with Retailer to bundle both chilled water and power together to sell to end users in DCP

ANNEX D: SCOPE OF RFI

1. This RFI seeks to gather the following information for which the onsite power/chilled water infrastructure for DCP can be best developed.

2. Technical Design of the Plant

Respondents are to propose the set up of the Plant for the DCP.

- 2.1 The Plant is expected to occupy approximately 4.5Ha of land area, and is expected to be built on a raised platform of at least 1 metre above flood level.
- 2.2 The capacity of the Plant should be less than 500MW and must at least fulfil the power and chilled water requirements from the end users in DCP. The range for power⁶ requirement, excluding chilled water requirement is estimated to be at least 160MW and at most 240MW. The range for chilled water⁷ requirement is estimated to be at least 50,000RT and at most 74,000RT.
- 2.3 The power and chilled water load profile from the end users in DCP is estimated to increase from 25% at initial operation to 90% over the next 5 years. Based on this estimated load profile, both big bang and modular implementation of the Plant could be considered.
- 2.4 Plant Developer shall strive to achieve the highest level of redundancy and resiliency required by high end end users in DCP. However, it is possible that end users in DCP depend on the grid as their primary source of power and build their standby generator sets for backup. Alternatively, they can also depend on the Plant for both primary and backup sources for chilled water. Thus, the final redundancy design of the Plant for chilled water should arise as a discussion outcome between the Plant Developer and end users themselves. In view of this, the Plant must provide the necessary redundancy for chilled water to support the end users' requirements.
- 2.5 The Plant is expected to work based on a dual fuel system of natural gas and diesel. In this respect, diesel may be considered as an alternative fuel to natural gas.
- 2.6 For safety and resiliency purposes, underground diesel storage is preferred and this must be in conjunction with current EMA's requirement of a Generation Licensee to provide fuel reserves to last at least 90 days for operation of the Licensee's authorised business.

⁶ Based on the following assumptions:

- Ratio of electrical load for IT servers : CRAC & other M&E : Chillers is 60 : 20 : 20
- Power density for IT servers is 1.6kW/m²
- NLA is solely used for IT servers
- Power requirement range excludes electrical load for chillers

⁷ Based on industry's average cooling density of 0.66 RT/m²

2.7 Based on the need for efficiency and cost-effectiveness, a modular tri-generation solution, supplemented with electric chillers, is the suggested optimal solution for the DCP (Figure 4). Other configurations considered are a Combined-Cycle Gas Turbine (CCGT) power plant with absorption and electrical chillers (Figure 5), as well as Co-generation plant with absorption chillers (Figure 6).

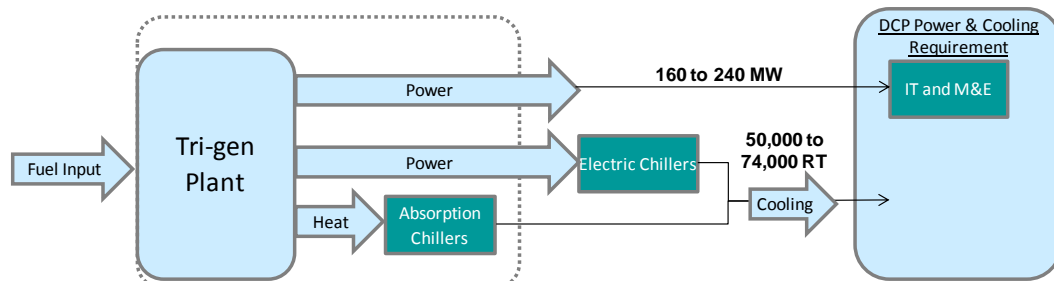

Figure 4: Trigen plant, supplemented with electrical chillers

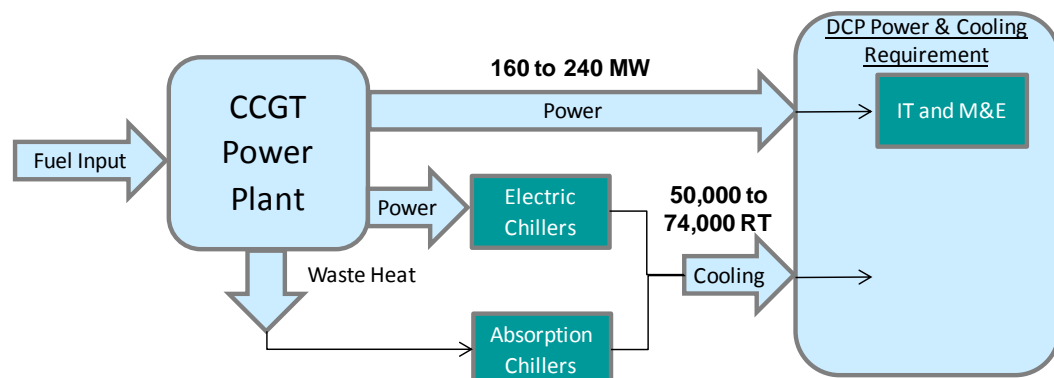

Figure 5: CCGT power plant with electrical and absorption chillers

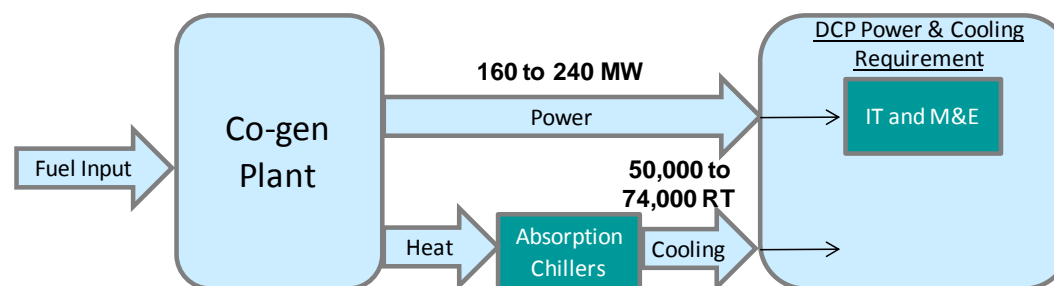

Figure 6: Co-generation power plant with absorption chillers

2.8 However, the Respondent may also suggest alternative solution(s) that is more cost-effective, more efficient, scalable, and able to meet the needs of end users in DCP. The Respondent may also consider the embedded generation model as a possible alternative solution, as long as it fulfils EMA's requirements of an embedded generation⁸ (Figure 7).

⁸ For rules on embedded generation, please refer to Paragraph 1.1 and 1.2 http://www.ema.gov.sg/media/com_consultations/attachments/1258529066Review_of_Policy_on_Direct_Supply_final.pdf

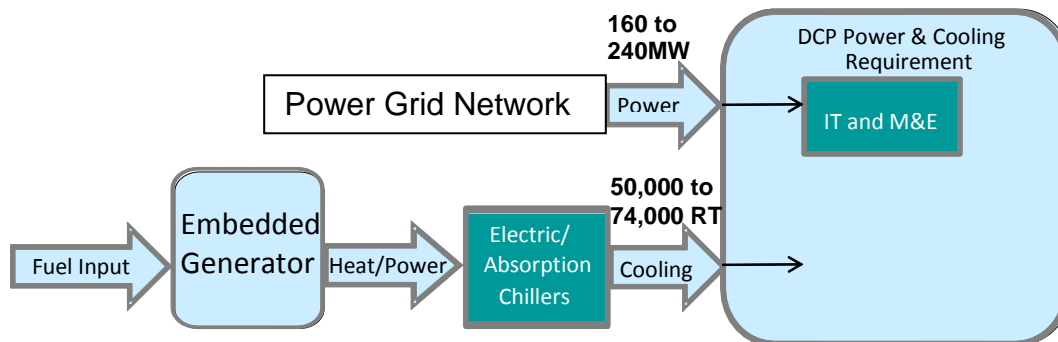

Figure 7: Embedded Generation Model

2.9 Respondents are to provide the following relevant information:

- i. Possible configurations for the Plant, which can fulfil the DCP's power and chilled water requirements and provide the required reliability and redundancy.
- ii. Details and timeline of the installation and commissioning of the Plant to meet the estimated power and chilled water profile, including the factors of consideration (cost, time taken to build and commission, commercial aspects) for a modular approach and/or a big-bang approach.
- iii. Layout of the proposal for the Plant, including the main sub-system (i.e, gas turbine, generator, switchhouse, natural gas receiving station, diesel storage, cooling water system, etc). The layout should indicate the dimensions (in metrics).
- iv. Details on how redundancy is ensured for the provisioning of chilled water, the relevant Service Level Agreements (SLAs) and maintenance activities to ensure a high availability for chilled water.
- v. Considerations (commercial, design and building, maintenance aspects) for onsite underground diesel storage, as compared to the usual practice by Generation Licensees to have onsite diesel storage above ground.
- vi. Other additional solutions and services as to how the needs of end users in DCP can be best addressed.

3. Regulatory Requirements

- 3.1 The Plant Developer has to apply for a Generation Licence to generate power, register as a market participant and trade in the wholesale electricity market. The Plant Developer is also required to apply for a Retail Licence if it decides to sell the power it generates to the end users.
- 3.2 The Plant Developer is expected to design the Plant such that it meets the allowable fault current contribution limit, in accordance with SP PowerGrid

Ltd's fault current requirements, to facilitate its connection to the transmission system.

- 3.3 The Plant will run on Liquefied Natural Gas (LNG). This is in accordance with the Policy on Gas Import Control issued by EMA which stated that all new gas demand will have to be met either through LNG or existing PNG⁹ once the LNG terminal is in commercial operation.
- 3.4 The Plant must fulfil NEA's requirements on acceptable emission limits for air, soil, water and noise pollution.
- 3.5 The Plant must fulfil any other relevant government requirements.
- 3.6 Respondents are to provide the following relevant information:
 - i. Expected fault current contribution of the Plant, based on the proposed set up of the Plant.
 - ii. Measures to alleviate fault current contribution to ensure that it stays within the allowable fault current contribution limit.
 - iii. Estimated gas requirement by the Plant, i.e. volume of gas, gas specifications like intake pressure, plant tripping pressure, and etc.
 - iv. Estimated emission levels for air, noise, and trade effluent discharge and management of hazardous chemicals and toxic wastes.
 - v. Measures and equipments that can be put in place to minimise or prevent pollution.
 - vi. Details of the monitoring programme, such as parameters monitored, type of monitoring equipment, frequency of monitoring for air, noise, water, hazardous chemicals and toxic wastes.

4. Commercial/Business Requirements

- 4.1 The chilled water component in the bundled pricing for power and chilled water is to be offered to the end users in DCP for free.
- 4.2 The Respondent may specify the conditions to enable free chilled water to be provided as part of the bundled pricing to the end users in DCP, and at the same time, allows the Plant Developer to recover the cost of chilled water.
- 4.3 Alternatively, if free chilled water is not a feasible option, Respondent may also suggest alternative pricing and pricing formula for chilled water that is cost-effective, competitive, and able to meet the needs of end users in DCP.

⁹ Refers to PNG contracted via gas sales agreements by gas importers before 21 August 2006

- 4.4 With reference to **Annex C: Section 7**, the Respondent may also suggest possible arrangements which can incentivise the Plant Developer to bundle both power and chilled water such that cheaper chilled water can be offered, for e.g. long term contracts for power and chilled water.
- 4.5 The Plant Developer is required to lay the reticulation network and bear the full costs of distributing chilled water directly to the end users in DCP. Early detection systems such as leak detection cables and pressure monitoring systems must also be put in place to avoid leakage of chilled water.
- 4.6 The Plant is estimated to take 2 years for construction and commissioning and is stipulated to commence commercial operation by December 2013. To ensure business continuity for end users in DCP, the Plant Developer will be bound by contractual obligations to meet the timeline in construction and commissioning of the Plant.
- 4.7 In the event where the Plant failed to commence commercial operations by December 2013, the Plant Developer must also put in place steps to provide power and chilled water to the end users in DCP during the interim.
- 4.8 In case of insolvency, the Plant Developer must allow government step-in rights to ensure business continuity for end users in DCP.
- 4.9 Respondents are to provide the following relevant information:
- i. List of conditions to enable free chilled water to be provided, and at the same time, allow Plant Developer to recover costs of producing chilled water.
 - ii. Alternatively, if chilled water cannot be provided for free, Respondent shall suggest alternative pricing and pricing formula for chilled water which can allow cost recovery and ensure competitive pricing to the end users in DCP.
 - iii. Possible arrangements to incentivise the bundling of power and chilled water such that cheaper chilled water can be provided.
 - iv. Any commercial/business consideration with regards to the 2-year period to construct and commission of the Plant, which can potentially delay the Plant's commercial operation stipulated in December 2013.
 - v. Proposed interim solutions in the event where the Plant is unable to commercially operate by December 2013.
 - vi. Recommended conditions to allow government step-in rights
 - vii. Other additional commercial suggestions as to how the needs of end users in DCP can be best addressed.

- viii. Any business and commercial risk which the Plant Developer faces and proposal of specific terms and conditions to lower such risks, for e.g. mandating Plant Developer as the primary provider for chilled water to lower risks of uncommitted demand.

ANNEX E: GUIDELINES FOR SUBMISSION OF RFI

Information on Cover Letter

1. Respondent is to provide an executive summary of the proposal highlighting the salient points of their submission. It shall contain the following:
 - a. Summary of background of organization (or consortium), organization's current role in this RFI proposal.
 - b. Summary of identified areas of the RFI that parties are responding to, outlining the proposals, comments and relevant information.
 - c. Signatures of authorized representatives of the organization (or consortium) and the lead organization's seal.

Information on Respondent

2. In order for IDA to gain a deeper understanding and contextualize the information received, additional background information of the Respondent is required. As such, the Respondent is requested to provide the following as part of their submission:
 - a. Details of the organization's (or consortium's) background, including role in the proposal.
 - b. Details of identified areas of the RFI that Respondent is responding to, detailing the proposals, comments and relevant information.
 - c. Past participation and role in prior initiatives similar to this RFI.
 - d. Past participation and role in prior initiatives relating to the relevant Singapore Government initiatives.

-----END OF DOCUMENT-----