



**Technical Specification**  
for  
**Asymmetric Digital Subscriber Line Modems**

IDA TS ADSL  
Issue 1 Rev 2, May 2011

Info-Communications Development Authority of Singapore  
Resource Management & Standards  
10 Pasir Panjang Road  
#10-01 Mapletree Business City  
Singapore 117438

© Copyright of IDA, 2011

This document may be downloaded from the IDA website at <http://www.ida.gov.sg> and shall not be distributed without written permission from IDA

# Contents

		<b>Page</b>
<b>Part A</b>	<b>Introduction</b>	<b>3</b>
<b>1</b>	<b>Scope</b>	<b>3</b>
<b>2</b>	<b>General Application Reference Models</b>	<b>4</b>
<b>3</b>	<b>ATU-R Transmitter Reference Model for ATM transport</b>	<b>6</b>
<b>4</b>	<b>General Requirements</b>	<b>7</b>
4.1	Power Supply	7
4.2	Identification of Equipment	7
4.3	Safety Requirements	7
4.4	Electromagnetic Compatibility (EMC) Requirements	7
<b>Part B</b>	<b>Asymmetric Digital Subscriber Line (ADSL) Transceivers</b> (ITU-T Recommendation G.992.1, June 1999)	<b>8</b>
<b>Part C</b>	<b>Splitterless Asymmetric Digital Subscriber Line (ADSL) Transceivers</b> (ITU-T Recommendation G.992.2, June 1999)	<b>12</b>
<b>Part D</b>	<b>Asymmetric Digital Subscriber Line Transceivers 2 (ADSL2)</b> (ITU-T Recommendation G.992.3, July 2002)	<b>14</b>
<b>Part E</b>	<b>Splitterless Asymmetric Digital Subscriber Line Transceivers 2 (Splitterless ADSL2)</b> (ITU-T Recommendation G.992.4, July 2002)	<b>18</b>
<b>Part F</b>	<b>Asymmetric Digital Subscriber Line (ADSL) Transceivers – Extended Bandwidth (ADSL2+)</b> (ITU-T Recommendation G.992.5, May 2003)	<b>20</b>
<b>Annex A</b>	<b>Network Specific Implementation Options</b>	<b>23</b>
<b>Annex B</b>	<b>References</b>	<b>24</b>
<b>Annex C</b>	<b>Corrigendum/Addendum</b> Changes to IDA TS ADSL Issue 1 Rev 1 (Apr 06) Changes to IDA TS ADSL Issue 1 (Jul 05) Changes to IDA TS ADSL 1 Issue 1 Rev 1 (Jun 2000) and TS ADSL 2 Issue 1 (Sep 2000)	<b>25</b>

**This Specification is subject to review and revision.**

---

## Part A Introduction

### 1 Scope

- 1.1 This Specification defines the physical layer characteristics of the Asymmetrical Digital Subscriber Line (ADSL) interface for both the first and second generation ADSL modems. The purpose of the Specification is to ensure proper inter-working of ADSL modems at the customer end (ATU-R) and network operator end (ATU-C) in terms of interaction and electrical characteristics. It defines a variety of frame bearers in connection with or without an underlying service. For example:
- (a) ADSL transmission simultaneously on the same pair with voice band service;
  - (b) ADSL transmission without any underlying service, optimized for deployment with ADSL over voice band service in the same binder cable.
- 1.2 ADSL modems may be designed for multi-mode operation, supporting one or more of the following ADSL modem standards:
- (a) ADSL standard (G.992.1) outlined in Part B of this Specification;
  - (b) Splitterless ADSL standard (G.992.2) outlined in Part C of this Specification;
  - (c) ADSL2 standard (G.992.3) outlined in Part D of this Specification;
  - (d) Splitterless ADSL2 standard (G.992.4) outlined in Part E of this Specification; and or
  - (e) ADSL2+ standard (G.992.5) outlined in Part F of this Specification.
- 1.3 ADSL modems, supporting the ADSL2, Splitterless ADSL2 or ADSL2+ standards, shall be backward compatible and capable of interacting with network equipment which supports only the ADSL and Splitterless ADSL standards.
- 1.4 Improvements noted in the second generation ADSL modems (G.992.3, G.992.4 and G.992.5) include:
- (a) Data rates exceeding 8 Mbit/s in the downstream and 800 kbit/s in the upstream are achieved with improved modulation efficiency, reduced framing overhead, higher coding gain, a more robust initialization procedure, and improved RFI and spectrum management tools.
  - (b) Diagnostic tools are available for trouble resolution during and after installation, in-service performance monitoring and upgrade qualification.
  - (c) ADSL2 modems come with two power management modes that help reduce the overall power consumption while maintaining the “always on” functionality for users.
  - (d) Seamless rate adaptation enables ADSL2 modems to change the data rate of connection while in operation without service interruption or bit errors.

## 2 General Application Reference Models

2.1 Standardising requirements for ADSL modems is carried out at the U interface points of the application reference models shown in Figures 1 to 4.

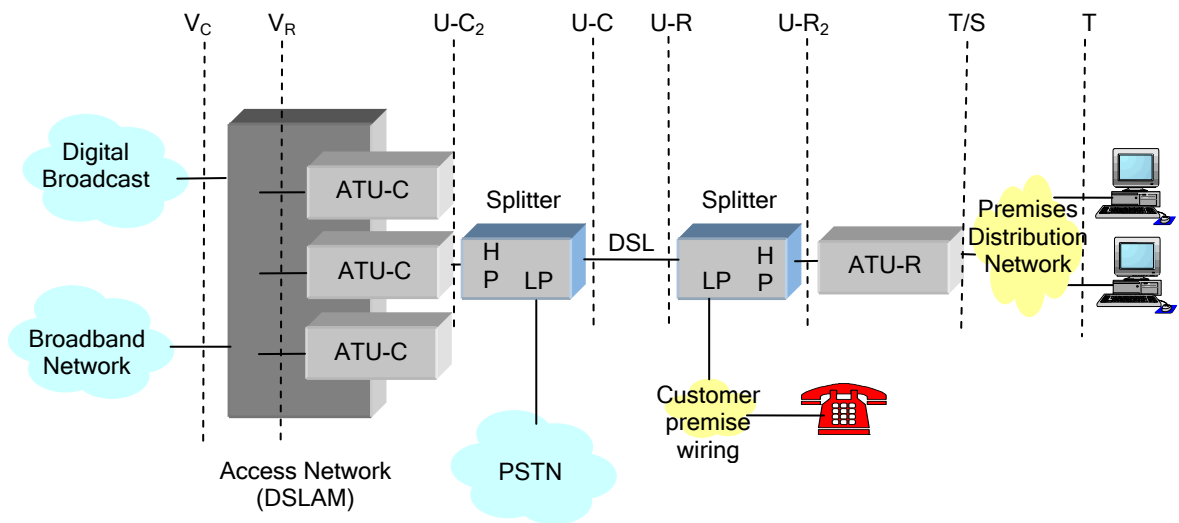

Figure 1: **Generic application reference model for remote deployment with splitter**

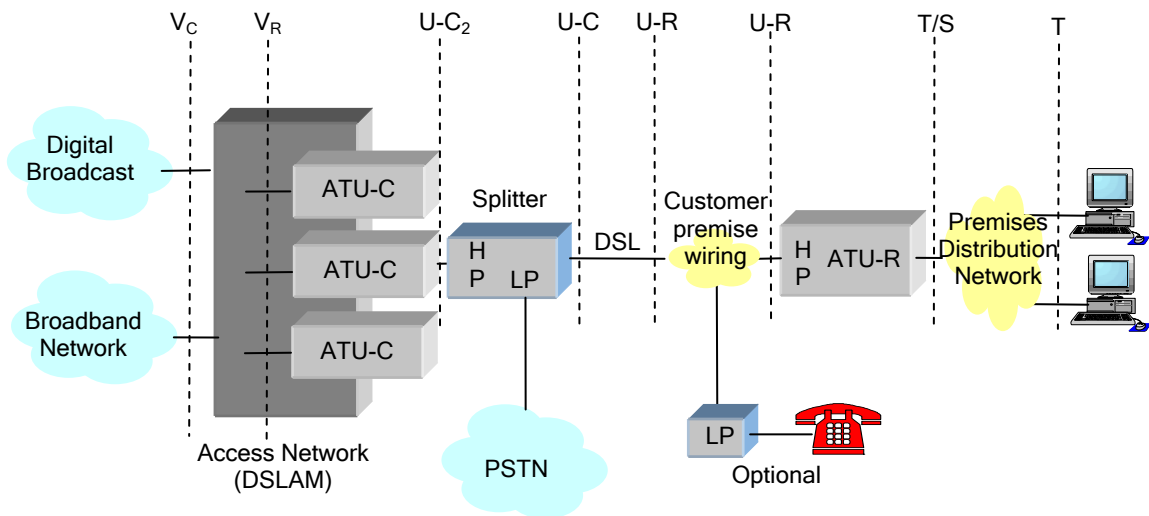

Figure 2: **Generic application reference model for splitterless remote deployment**

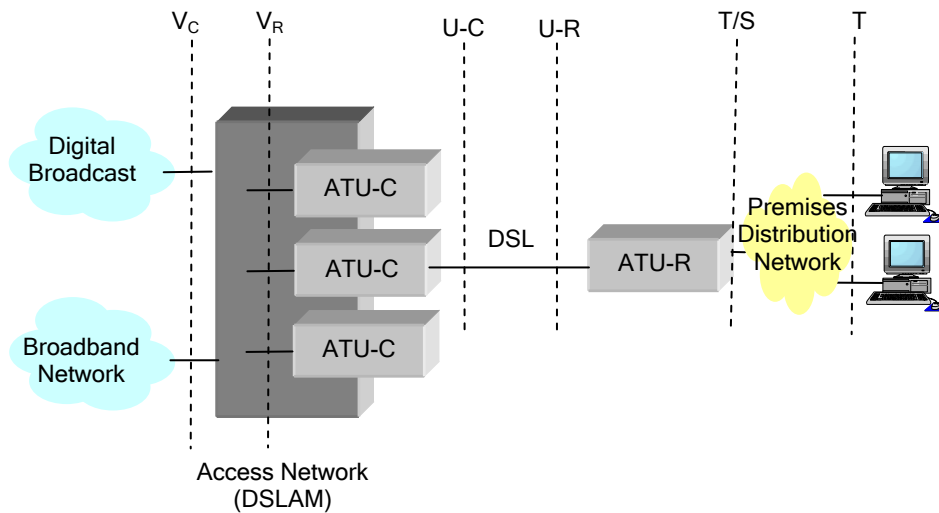

Figure 3: Data service application model

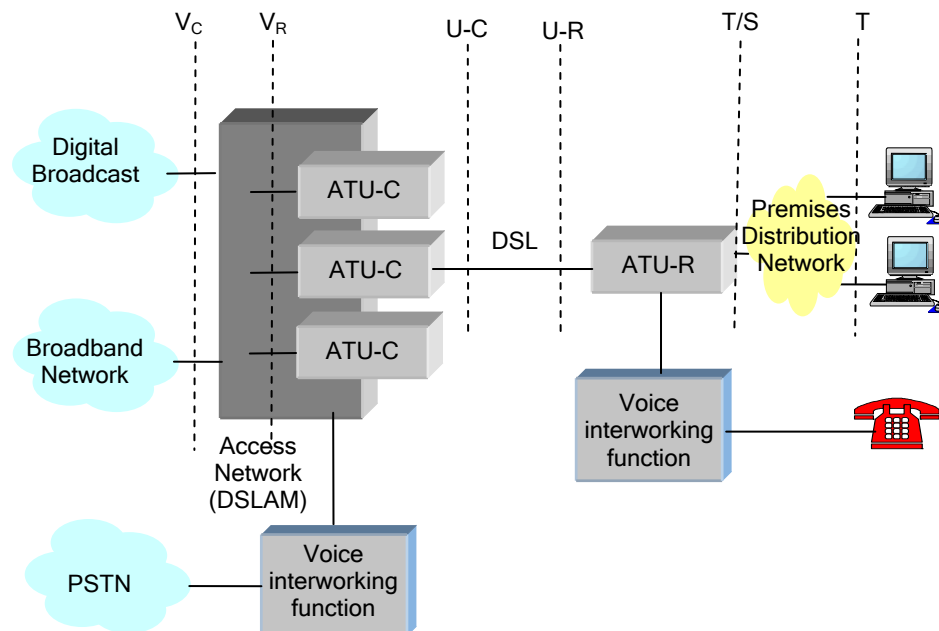

Figure 4: Voice over data service application model

**Notes:**

1. U-C and U-R interfaces are fully defined in this Specification.
2. V-C interface may consist of interfaces to one or more ATM switching systems.
3. High-pass filters, which are part of the splitters, may be integrated into the ATU-x; if so, U-C<sub>2</sub> and U-R<sub>2</sub> will become the same as U-C and U-R interfaces, respectively.
4. Due to asymmetry of signals on the line, transmitted signals shall be distinctively specified at the U-R and U-C reference points.
5. T/S may interface to in-building Ethernet, ATM25, USB, IEEE-1394 or home phone-line network.

2.2 The Premises Distribution Network (PDN) defines the technology for connecting subscribers' equipment (e.g. PCs) with the ADSL modem (ATU-R). This PDN may be provided as an Ethernet interface, ATM25, USB, IEEE-1394 or a HomePNA backbone. The selection depends mainly on subscribers' mix of services and network or service providers' preference in the ATU-R interfaces. Table 1 shows the PDN alternatives and their capabilities.

Table 1: Premises Distribution Network Alternatives and Capabilities					
PDN	ATM25	Ethernet	Home PDN	USB	IEEE-1394
<b>Bandwidth</b> *	25 Mbps	10/100 Mbps	10 Mbps+	12 Mbps (half-duplex)	400 Mbps (half-duplex)
<b>Reach</b>	50 m (Cat 5)	100 m (Cat 3)	500 feet in-house phone wiring	5 m (shielded)	4.6 m (shielded)
<b>Installation</b>	PC NIC	Most PCs require NIC	PC NIC	Included with PCs	Included with PCs
<b>Protocol</b>	Native ATM, PPP, RFC 1483	PPP via BMAP, PPPoE, tunnelling, bridging	PPPoE, bridging	PPP via BMAP	PPP via BMAP

\* Throughput to ADSL loop is limited by the ADSL data rate.

### 3 ATU-R Transmitter Reference Model for ATM Transport

3.1 Discrete Multi-Tone (DMT) is the selected encoding method for ADSL deployments. DMT encodes data into a 256 sub-carriers that are spaced at 4.3125 kHz. DMT relies in an Inverse Discrete Fourier Transform (IDFT) for data modulation into each carrier. DMT supports both the Synchronous Transfer Mode (STM) and Asynchronous Transfer Mode (ATM) of transport. However, the STM transport is not implemented locally.

3.2 In ATM mode (see Figure 5), a primary ATM cell stream (ATM0) conforming to ITU-T Rec. I.361 and I.432.1 passes through the transmission convergence stage and maps into LS0. Optionally, a second ATM cell stream (ATM1) will map into LS1. The last channel between the ATU-C and ATU-R is the Embedded Operations Channel (EOC) used for maintenance and monitoring.

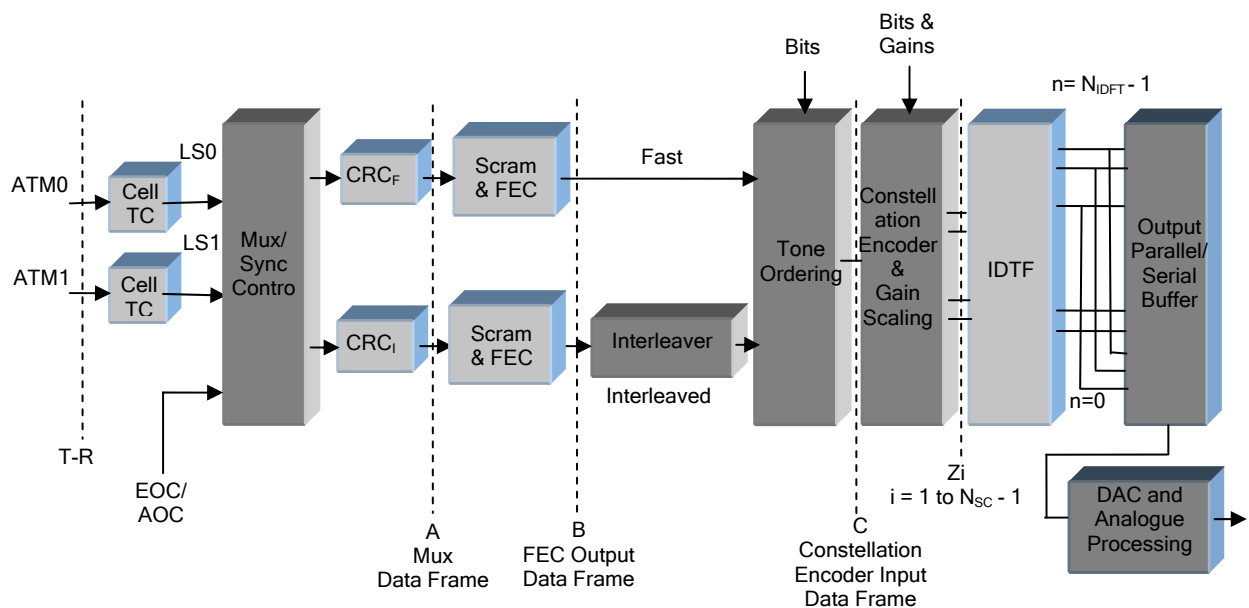

Figure 5: ATU-R Logical Functions for ATM Transport

## 4 General Requirements

### 4.1 Power Supply

The equipment may be a.c. powered or d.c. powered. For an a.c. powered equipment, the Specification shall be complied with when operating from an a.c. mains supply of voltage,  $230V \pm 10\%$  and frequency,  $50 \text{ Hz} \pm 2\%$ . Where external power supply is used, e.g. AC adaptor, it shall not affect the capability of the equipment to meet the Specification.

### 4.2 Identification of Equipment

The equipment shall be marked with the supplier or manufacturer's name or identification mark, and the supplier or manufacturer's model or type reference. The markings required shall be legible, indelible and readily visible.

### 4.3 Safety Requirements

The equipment shall be tested for compliance with the International Electrotechnical Commission IEC 60950-1 safety standard<sup>1</sup>. The requirements in IEC 60950-1 that are applicable to the equipment [e.g. class of equipment, type of telecommunication telephone voltage (TNV) circuit and types of components] shall be identified and complied with.

### 4.4 Electromagnetic Compatibility (EMC) Requirements

The equipment shall comply with the EMC requirements defined in CISPR 22.

#### NOTE

The following notations are used in the Specification:

CR	Conformance requirement defines features and functions that must be supported at minimum.
M	Mandatory requirements
O	Optional requirements, which become mandatory when features and functions are supported.
NA	Not Applicable
GID	General Information and Definitions

---

<sup>1</sup> The safety standard includes, among others, protection of telecommunications network service personnel and users of other equipment connected to the network from hazards in the equipment.

## Part B Asymmetric Digital Subscriber Line (ADSL) Transceivers

(ITU-T Recommendation G.992.1, June 1999)

TITLE	ITU-T Rec. G.992.1	CR	Remarks
<b>Scope</b>	<b>1</b>	GID	
System reference model	1.1	GID	
Objectives	1.2	GID	
<b>References</b>	<b>2</b>	GID	
<b>Definitions</b>	<b>3</b>	GID	
<b>Abbreviations</b>	<b>4</b>	GID	
<b>Reference models</b>	<b>5</b>	GID	
ATU-C transmitter reference models	5.1	GID	
ATU-R transmitter reference models	5.2	M	STM transport is not supported in local implementation. ATM mode of transport shall be supported.
<b>Transport capacity</b>	<b>6</b>	GID	
Transport of STM data	6.1	NA	STM transport is not supported in local implementation.
Transport of ATM data	6.2	M	Single latency mode shall be support whereas the need for dual latency is optional. Bearer channel AS0 shall support multiples of 32 kbit/s from 32 kbit/s to 6.144 Mbit/s. Bearer channel LS0 shall support multiples of 32 kbit/s from 32 kbit/s to 640 kbit/s. When AS1 and LS1 are provided, they shall support data rates shown in Table 6-1/G.992.1.
ADSL system overheads and total bit rates	6.3	M	Full overhead framing mode shall be supported. Reduced overhead framing mode is optional.
<b>ATU-C Functional Characteristics</b>	<b>7</b>	GID	
STM transmission protocol specific functionalities	7.1	GID	The provision of STM transport mode is network dependent.
ATM transport protocol specific functionalities	7.2	GID	The provision of ATM transport mode is network dependent.
Network timing reference	7.3	GID	
Framing	7.4	GID	An ATU-C shall indicate during initialisation the modes and versions of the overhead used by the modems. StarHub's network supports framing structure 0. Other structures are provided as options.
Scramblers	7.5	GID	
Forward error correction	7.6	GID	
Tone ordering	7.7	GID	

TITLE	ITU-T Rec. G.992.1	CR	Remarks
Constellation encoder (Trellis code version)	7.8	GID	
Constellation encoder (No trellis coding)	7.9	GID	
Gain scaling	7.10	GID	
Modulation	7.11	GID	$N_{SC} = 256$ $N_{IDFT} = 512$
Cyclic prefix	7.12	GID	
Transmitter dynamic range	7.13	GID	
ATU-C downstream transmitter spectral masks	7.14	GID	
Dual bit mapping and rate conversion (Annex C only)	7.15	GID	
FEXT bit mapping (Annex C only)	7.16	GID	
<b>ATU-R Functional Characteristics</b>	<b>8</b>	<b>M</b>	Framing modes for ATM transport shall be supported.
STM transmission protocol specific functionalities	8.1	NA	STM transport is not supported in local implementation.
ATM transport protocol specific functionalities	8.2	M	
Network timing reference	8.3	O	
Framing	8.4	M	StarHub's network supports framing structure 0. Other structures are provided as options. Hyperframe and Subframe structures are not supported.
Scramblers	8.5	M	
Forward error correction	8.6	M	
Tone ordering	8.7	M	
Constellation encoder - Trellis version	8.8	M	
Constellation encoder - Uncoded version	8.9	M	
Gain scaling	8.10	M	
Modulation	8.11	M	$N_{SC} = 32$ $N_{IDFT} = 64$
Cyclic prefix	8.12	M	
Transmitter dynamic range	8.13	M	
ATU-R upstream transmitter spectral response	8.14	M	
Dual bit mapping and rate conversion (Annex C only)	8.15	NA	
FEXT bit mapping (Annex C only)	8.16	NA	
EOC operations and maintenance	9	M	
Clear EOC	9.1	O	
Embedded operations channel (EOC) requirements	9.2	M	Shall comply with requirements for communication between the ATU-C and ATU-R for in-service and out-of-service maintenance.
In-service performance monitoring and surveillance	9.3	M	STM data path related primitives are not applicable.

TITLE	ITU-T Rec. G.992.1	CR	Remarks
<b>Initialization</b>	<b>10</b>	M	
Overview	10.1	M	Shall be implemented using frequency-division-duplexing (FDD) or echo cancelling (EC). Initialisation with hyperframe is not applicable.
Handshake – ATU-C	10.2	GID	
Handshake – ATU-R	10.3	O	
Transceiver training – ATU-C	10.4	M	
Transceiver training – ATU-R	10.5	M	
Channel analysis (ATU-C)	10.6	M	
Channel analysis (ATU-R)	10.7	M	
Exchange – ATU-C	10.8	M	
Exchange – ATU-R	10.9	M	
<b>AOC on-line adaptation and reconfiguration</b>	<b>11</b>	M	
The ADSL overhead control (AOC) channel	11.1	M	
On-line adaptation – Bit swapping	11.2	O	
<b>Specific requirements for an ADSL system operating in the frequency band above POTS</b>	<b>Annex A</b>	M	The transmitter spectral response above 4 kHz falls under the PSD mask specified in Figure A.3/G.992.1.  The aggregate power level in the 25.875 kHz to 138 kHz frequency band does not exceed the 12.5 dBm limit specified in A.2.4.3.1/G.992.1.  The longitudinal balance at the U-R interface shall be > 40 dB over the frequency range 30 kHz to 1104 kHz (A.4.3.1/G.992.1).
<b>Specific requirements for an ADSL system operating in the frequency band above ISDN as defined in ITU-T Rec. G.961 Appendices I and II</b>	<b>Annex B</b>	NA	
<b>Specific requirements for an ADSL system operating in the same cable as ISDN as defined in ITU-T Rec. G.961 Appendix III</b>	<b>Annex C</b>	NA	
<b>ATU-C and ATU-R state diagrams</b>	<b>Annex D</b>	GID	

TITLE	ITU-T Rec. G.992.1	CR	Remarks
<b>POTS and ISDN-BA Splitters</b>	<b>Annex E</b>	GID	
<b>Type 1 - European</b>	<b>E.1</b>	GID	If applicable, POTS splitter shall comply with the requirements specified in Annex L, IDA TS PSTN.
Impedance Matching	E.1.1	GID	If applicable, impedance matching shall be 600Ω.
Return loss	E.1.2	GID	If applicable, minimum value of return loss against 600Ω shall be 14 dB.
Insertion loss	E.1.3	GID	If applicable, insertion loss shall be < 1 dB at 1 kHz for 600Ω.
Insertion loss distortion	E.1.4	GID	If applicable, insertion loss distortion (300 Hz to 3400 Hz) shall be < ± 1 dB at 600Ω.
Isolation	E.1.5	GID	If applicable, isolation resistance, branch-earth shall be > 5 MΩ; term =∞; 100 Vd.c. Isolation resistance, branch-branch shall be > 1 MΩ; term =∞; 100 Vd.c. DC resistance shall be < 80Ω; term = 0 Ω.
Signal power	E.1.6	GID	If applicable, maximum power level in 300 Hz to 3400 Hz shall be < -6 dBm when measured with 600 Ω termination.
Ringling	E.1.7	GID	If applicable, ringing frequency is 24 Hz; ringing voltage is ≤ 75Vrms.
Unbalance about earth	E.1.8	GID	If applicable, impedance unbalance about earth, LCL shall > 40 dB, 300 Hz to 600 Hz and > 46 dB, 600 Hz to 3400 Hz, terminated with 600Ω.
Frequencies and levels for pulse metering	E.1.9	NA	
<b>Type 2 – North America</b>	<b>E.2</b>	NA	
<b>Type 3 – ADSL above ISDN (ITU-T G.961 Appendix I or II)</b>	<b>E.3</b>	NA	
<b>Type 4 – Type for Japan</b>	<b>E.4</b>	NA	
<b>ATU-x Classification and Performance for Region A (Other than Europe)</b>	<b>Annex F</b>	GID	
<b>ATU-x Classification and Performance for Region B (Europe)</b>	<b>Annex G</b>	GID	
<b>ATM Layer to Physical Layer Logical Interface</b>	<b>Appendix I</b>	GID	
<b>Dynamic (on-line) Rate Adaptation</b>	<b>Appendix II</b>	GID	
<b>Compatibility with other customer premise equipment</b>	<b>Appendix III</b>	GID	
<b>Bibliography</b>	<b>Appendix IV</b>	GID	

## Part C Splitterless Asymmetric Digital Subscriber Line (ADSL) Transceivers

(ITU-T Recommendation G.992.2, June 1999)

TITLE	ITU-T Rec. G.992.2	CR	Remarks
<b>Scope</b>	<b>1</b>	GID	
<b>References</b>	<b>2</b>	GID	
<b>Definitions and abbreviations</b>	<b>3</b>	GID	
<b>Reference models</b>	<b>4</b>	GID	Support of ATM is required. ADSL modem (ATU-R) shall support bearer channel AS0 downstream and LS0 upstream.
<b>Transport capacity</b>	<b>5</b>	M	ADSL modem (ATU-R) shall support the transport of a single duplex bearer channel. Bearer channel AS0 shall support multiples of 32 kbit/s from 64 kbit/s to 1.536 Mbit/s. Bearer channel LS0 shall support multiples of 32 kbit/s from 32 kbit/s to 512 kbit/s.
<b>ATU interfaces</b>	<b>6</b>	–	Heading
ATU interface for ATM transport	6.1	M	
ATU PMD to TC Logical Interface	6.2	GID	
<b>ATU Functional Characteristics</b>	<b>7</b>	–	Heading
ATM Transport Protocol Specific Functionalities	7.1	M	ITU-T Rec. I.432.1
Network Timing Reference	7.2	O	
Framing	7.3	M	The framing is equivalent to the “reduced overhead mode with merged fast and sync bytes” as defined in G.992.1/8.4.1.2.2 using the “interleaved buffer” definition.
Scrambler	7.4	M	
Reed Solomon Forward Error Correction	7.5	M	
Interleaver	7.6	M	
Tone ordering	7.7	M	
Constellation encoder	7.8	M	
Gain scaling	7.9	M	
Modulation	7.10	M	
Cyclic prefix	7.11	M	
Transmitter dynamic range	7.12	M	
<b>Embedded operations channel (EOC)</b>	<b>8</b>	–	Heading
EOC introduction	8.1	M	
EOC message encoding	8.2	M	
EOC message description	8.3	M	
EOC Protocol	8.4	M	
Clear EOC	8.5	O	

TITLE	ITU-T Rec. G.992.2	CR	Remarks
<b>ADSL overhead channel (AOC)</b>	<b>9</b>	–	Heading
The ADSL overhead control (AOC) channel introduction	9.1	O	
AOC message encoding	9.2	M	
Bit swap operation	9.3	O	
AOC protocol	9.4	M	
<b>In-service performance monitoring and surveillance</b>	<b>10</b>	GID	
ADSL line related primitives	10.1	M	
ATM data path related primitives	10.2	M	
Other ADSL indicators, parameters and signals	10.3	M	ADSL modem (ATU-R) may optionally provide near-end and far-end failure counters.
Test parameters	10.4	M	
Other failures and parameters	10.5	M	
<b>Initialization</b>	<b>11</b>	–	Heading
Overview	11.1	M	Implement either non-overlapped spectrum mode (Annex A/G.992.2) or overlapped spectrum mode (Annex B/G.992.2)
Handshake – ATU-C	11.2	GID	
Handshake – ATU-R	11.3	M	
Handshake power levels	11.4	M	
Escape from Handshake to Fast Retrain	11.5	O	
Power Levels in Transceiver Training, Channel Analysis and Exchange	11.6	M	
Transceiver training – ATU-C	11.7	M	
Transceiver training – ATU-R	11.8	M	
Channel analysis (ATU-C)	11.9	M	
Channel analysis (ATU-R)	11.10	M	
Exchange – ATU-C	11.11	M	
Exchange – ATU-R	11.12	M	
<b>Fast retrain</b>	<b>12</b>	O	
<b>Power management</b>	<b>13</b>	O	
<b>Non-overlapped Spectrum Operation</b>	<b>Annex A</b>	M	ADSL modem shall comply with either the ATU-R transmitter PSD mask and aggregate power level specified in Annex A/G.992.2 or in Annex B/G.992.2
<b>Overlapped Spectrum Operation</b>	<b>Annex B</b>	M	
<b>ADSL above POTS co-existing in the same binder as TCM-ISDN DSL</b>	<b>Annex C</b>	GID	
<b>System Performance for North America</b>	<b>Annex D</b>	GID	
<b>System Performance for Europe</b>	<b>Annex E</b>	GID	
–	<b>Appendix I</b>	GID	
<b>Guide to scenarios for the implementation of the various procedures in Recommendations G.994.1 and G.992.2</b>	<b>Appendix II</b>	GID	
<b>Compatibility with other Customer Premises Equipment</b>	<b>Appendix III</b>	O	“M” if applicable.

## Part D Asymmetric Digital Subscriber Line Transceivers 2 (ADSL2)

(ITU-T Recommendation G.992.3, July 2002)

TITLE	ITU-T Rec. G.992.3	CR	Remarks
Scope	1	GID	
References	2	GID	
Definitions	3	GID	
Abbreviations	4	GID	
Reference models	5	GID	Application models may include: <ol style="list-style-type: none"> <li>1. Generic application reference model for remote deployment with splitter</li> <li>2. Generic application reference model for splitterless remote deployment</li> <li>3. Data service application model</li> <li>4. Data with POTS service application model</li> <li>5. Data with ISDN service application model</li> <li>6. Voice over data service application model</li> </ol>
<b>Transport Protocol Specific Transmission Convergence (TPS-TC) function</b>	<b>6</b>	-	Heading
Transport capabilities	6.1	M	ADSL modem (ATU-R) shall support the procedures for transport of the output frame bearers of one to four unidirectional TPS-TC functions in both the upstream and downstream directions. The TPS-TC function may be of differing types, and each type is defined in Annex K/G.992.3.
Interface signals and primitives	6.2	M	
Control parameters	6.3	M	ADSL modem shall support at least one combination of a TPS-TC function (of a type defined in Annex K/G.992.3). The control parameters of TPS-TC function shall be as defined in Table 6-1/G.992.3.
Data plane procedures	6.4	M	
Management plane procedures	6.5	O	Each TPS-TC function may provide local management primitives as defined in Annex K/G.992.3.
Initialization procedure	6.6	M	
On-line reconfiguration	6.7	M	On-line reconfiguration procedures are defined uniquely for each TPS-TC type in Annex K/G.992.3.
Power management mode	6.8	M	

TITLE	ITU-T Rec. G.992.3	CR	Remarks
<b>Physical Media Specific Transmission Convergence (PMS-TC) function</b>	<b>7</b>	–	Heading
Transport capabilities	7.1	M	ADSL modem shall support the PMS-TC function for multiplexing and transporting several channels of information.
Additional functions	7.2	M	
Block interface signals and primitives	7.3	M	
Block diagram and internal reference point signals	7.4	M	
Control parameters	7.5	M	
Frame structure	7.6	M	
Data plane procedures	7.7	M	An ATU-C may optionally transport an 8 kHz timing marker as NTR.
Control plane procedures	7.8	M	
Management plane procedures	7.9	M	
Initialization procedures	7.10	M	
On-line reconfiguration	7.11	M	
Power management mode	7.12	M	
<b>Physical media dependent function</b>	<b>8</b>	–	Heading
Transport capabilities	8.1	M	ADSL modem shall support the PMD function for transporting a bitstream over the physical medium (i.e. over the copper pairs) in both the upstream and downstream directions.
Additional functions	8.2	M	
Block interface signals and primitives	8.3	M	
Block diagram and internal reference point signals	8.4	M	
Control parameters	8.5	M	
Constellation encoder for data symbols	8.6	M	
Constellation encoder for synchronization and L2 exit symbols	8.7	M	
Modulation	8.8	M	
Transmitter dynamic range	8.9	M	
Transmitter spectral masks	8.10	M	
Control plane procedures	8.11	M	
Management plane procedures	8.12	M	
Initialization procedures	8.13	M	ADSL modem may implement FDM or EC to separate upstream and downstream signals.
Short initialization procedures	8.14	O	Short Initialization Sequence shall be optional. If the Short Initialization Sequence is supported, the ADSL modem should also support unbalanced bitswap.
Loop diagnostics mode procedures	8.15	M	
On-line reconfiguration of the PMD function	8.16	M	
Power management in the PMD function	8.17	M	

TITLE	ITU-T Rec. G.992.3	CR	Remarks
<b>Management Protocol Specific Transmission Convergence (MPS-TC) functions</b>	<b>9</b>	GID	
Transport functions	9.1	M	As a management plane element, the MPS-TC provides transport of the clear eoc and command messages and ATU-R management defects and anomalies.
Additional functions	9.2	M	
Block interface signals and primitives	9.3	M	
Management plane procedures	9.4	M	
Power management	9.5	M	
<b>Dynamic behaviour</b>	<b>10</b>	M	
Initialization	10.1	M	
On-line Reconfiguration (OLR)	10.2	M	
Power management	10.3	M	
<b>Specific requirements for an ADSL system operating in the frequency band above POTS</b>	<b>Annex A</b>	M	ADSL modem shall comply with the ATU-R upstream transmit spectral mask and aggregate transport power specified in A.2/G.992.3. With overlapped spectrum, the widest possible band used is 25.875 to 1104 kHz. With non-overlapped spectrum, the widest possible band used is 138 to 1104 kHz.
<b>Specific requirements for an ADSL system operating in the frequency band above ISDN as defined in ITU-T Rec. G.961 Appendices I and II</b>	<b>Annex B</b>	NA	
<b>Specific requirements for an ADSL system operating in the same cable as ISDN as defined in ITU-T Rec. G.961 Appendix III</b>	<b>Annex C</b>	NA	
<b>ATU-C and ATU-R state diagrams</b>	<b>Annex D</b>	GID	
<b>POTS and ISDN Basic Access Splitters</b>	<b>Annex E</b>	GID	
<b>Type 1 – POTS splitter – Europe</b>	<b>E.1</b>	O	The total (across tip and ring at the POTS port) impedance in the 2 to 10 MHz frequency band should be at least 160 $\Omega$ .
<b>Type 2 – POTS splitter – North America</b>	<b>E.2</b>	O	The total (across tip and ring at the POTS port) impedance in the 2 to 10 MHz frequency band should be at least 160 $\Omega$ .
<b>Type 3 – ISDN (ITU-T Rec. G.961 Appendix I or II) Splitter – Europe</b>	<b>E.3</b>	NA	
<b>Type 4 – POTS splitter – Japan</b>	<b>E.4</b>	O	
<b>ATU-x performance requirements for region A (North America)</b>	<b>Annex F</b>	O	
<b>ATU-x performance requirements for region B (Europe)</b>	<b>Annex G</b>	O	

TITLE	ITU-T Rec. G.992.3	CR	Remarks
<b>Specific requirements for a synchronized symmetrical DSL (SSDSL) system operating in the same cable binder as ISDN as defined in ITU-T Rec. G.961 Appendix III</b>	<b>Annex H</b>	NA	
<b>All digital mode ADSL with improved spectral compatibility with ADSL over POTS</b>	<b>Annex I</b>	O	If applicable, the ADSL modem shall comply with the ATU-R upstream transmit spectral mask and aggregate transport power specified in I.2/G.992.3.  With overlapped spectrum, the widest possible band used is 3 to 1104 kHz.  With non-overlapped spectrum, the widest possible band used is 138 to 1104 kHz.
<b>All Digital Mode ADSL with improved spectral compatibility with ADSL over ISDN</b>	<b>Annex J</b>	NA	
<b>TPS-TC functional descriptions</b>	<b>Annex K</b>	GID	
STM Transmission Convergence (STM-TC) function	K.1	NA	
ATM Transmission Convergence (ATM-TC) function	K.2	M	
Packet transmission convergence function (PTM-TC)	K.3	O	
<b>ATM layer to physical layer logical interface</b>	<b>Appendix I</b>	GID	
<b>Compatibility with other customer premises equipment</b>	<b>Appendix II</b>	GID	
<b>The impact of primary protection devices on line balance</b>	<b>Appendix III</b>	GID	
<b>Bibliography</b>	<b>Appendix IV</b>	GID	

## Part E Splitterless Asymmetric Digital Subscriber Line Transceivers 2 (Splitterless ADSL2)

(ITU-T Recommendation G.992.4, July 2002)

TITLE	ITU-T Rec. G.992.4	CR	Remarks
Scope	1	GID	
References	2	GID	
Definitions	3	GID	
Abbreviations	4	GID	
Reference models	5	GID	Application models may include: <ol style="list-style-type: none"> <li>1. Generic application reference model for splitterless remote deployment</li> <li>2. Data service application model</li> <li>3. Data with POTS service application model</li> <li>4. Voice over data service application model</li> </ol>
Transport Protocol Specific Transmission Convergence (TPS-TC) function	6	M	ADSL modem shall support the TPS-TC transport capabilities and functions, interfaces and procedures as defined in § 6/G.992.3 and the appropriate clauses in Annex K/G.992.3.
Physical Media Specific Transmission Convergence (PMS-TC) function	7	M	ADSL modem shall support the PMS-TC transport capabilities and functions, interfaces, control variables, and procedures as defined in § 7/G.992.3 with exceptions given in § 7/G.992.4.
Physical media dependent function	8	M	ADSL modem shall support the PMD transport capabilities and functions, interfaces, control variables, and procedures as defined in § 8/G.992.3 with exceptions given in § 8/G.992.4.
Management Protocol Specific Transmission Convergence (MPS-TC) functions	9	M	ADSL modem shall support the MPS-TC transport capabilities and functions, interfaces, and procedures as defined in § 9/G.992.3 with exceptions given in § 9/G.992.4.
Control Protocol Specific Transmission Convergence (CPS-TC) functions	10	–	Further study by ITU-T
Dynamic behaviour	11	M	ADSL modem shall support dynamic behaviours, including initialization, power management, and on-line reconfiguration as defined in § 10/G.992.3.
Specific requirements for an ADSL system operating in the frequency band above POTS	Annex A	M	ADSL modem shall comply with the ATU-R upstream transmit spectral mask and aggregate transport power specified in A.2/G.992.3. With overlapped spectrum, the widest possible band used is 25.875 to 552 kHz. With non-overlapped spectrum, the widest possible band used is 138 to 552 kHz.
–	Annex B	–	Intentionally left blank
Specific requirements for an ADSL system operating in the same cable as ISDN as defined in ITU-T Rec. G.961 Appendix III	Annex C	NA	
ATU-C and ATU-R state diagrams	Annex D	GID	

TITLE	ITU-T Rec. G.992.4	CR	Remarks
<b>POTS and ISDN-BA splitters</b>	<b>Annex E</b>	GID	G.992.4 is intended for installation primarily without splitters. However, if splitters are provided for operation with POTS they shall comply with the requirements in Annex L of IDA TS PSTN.  The description of splitters for use with ISDN-BA described in Annex E/G.992.3 does not apply.
<b>ATU-x performance requirements for region A (North America)</b>	<b>Annex F</b>	–	Further study by ITU-T
–	<b>Annex G</b>	–	Intentionally left blank
–	<b>Annex H</b>	–	Intentionally left blank
<b>All digital mode ADSL with improved spectral compatibility with ADSL over POTS</b>	<b>Annex I</b>	O	If applicable, the ADSL modem shall comply with the ATU-R upstream transmit spectral mask and aggregate transport power specified in I.2/G.992.3.  With overlapped spectrum, the widest possible band used is 3 to 552 kHz.  With non-overlapped spectrum, the widest possible band used is 138 to 552 kHz.
–	<b>Annex J</b>	–	Intentionally left blank
<b>TPS-TC functional descriptions</b>	<b>Annex K</b>	M	The various TPS-TC types that may be used within the G.992.4 transceivers are described in Annex K/G.992.3. If a TPS-TC type is provided, it shall be implemented as described in Annex K/G.992.3 except as modified by § 6/G.992.3.

## Part F Asymmetric Digital Subscriber Line (ADSL) Transceivers – Extended Bandwidth (ADSL2+)

(ITU-T Recommendation G.992.5, May 2003)

TITLE	ITU-T Rec. G.992.5	CR	Remarks
<b>Scope</b>	<b>1</b>	GID	
<b>References</b>	<b>2</b>	GID	
<b>Definitions</b>	<b>3</b>	GID	
<b>Abbreviations</b>	<b>4</b>	GID	
<b>Reference models</b>	<b>5</b>	GID	Application models may include: <ol style="list-style-type: none"> <li>1. Generic application reference model for remote deployment with splitter</li> <li>2. Generic application reference model for splitterless remote deployment</li> <li>3. Data service application model</li> <li>4. Data with POTS service application model</li> <li>5. Data with ISDN service application model</li> <li>6. Voice over data service application model</li> </ol>
<b>Transport Protocol Specific Transmission Convergence (TPS-TC) function</b>	<b>6</b>	M	ADSL modem shall support the TPS-TC transport capabilities and functions, interfaces and procedures as defined in § 6/G.992.3 and the appropriate clauses in Annex K/G.992.3.
<b>Physical Media Specific Transmission Convergence (PMS-TC) function</b>	<b>7</b>	M	ADSL modem shall support the PMS-TC transport capabilities and functions, interfaces, control variables, and procedures as defined in § 7/G.992.3
<b>Physical media dependent function</b>	<b>8</b>	–	Heading
Transport capabilities	8.1	M	Refer to § 8.1/G.992.3
Additional functions	8.2	M	Refer to § 8.2/G.992.3
Block interface signals and primitives	8.3	M	Refer to § 8.3/G.992.3
Block diagram and internal reference point signals	8.4	M	Refer to § 8.4/G.992.3
Control parameters	8.5	M	The configuration of the PMD function is controlled by a set of control parameters defined in § 8.5.1/G.992.3.
Constellation encoder for data symbols	8.6	M	Refer to § 8.6/G.992.3
Constellation encoder for synchronization and L2 exit symbols	8.7	M	Refer to § 8.7/G.992.3
Modulation	8.8	M	
Transmitter dynamic range	8.9	M	Refer to § 8.9/G.992.3
Transmitter spectral masks	8.10	M	Refer to § 8.10/G.992.3
Control plane procedures	8.11	M	Refer to § 8.11/G.992.3
Management plane procedures	8.12	M	Refer to § 8.12/G.992.3
Initialization procedures	8.13	M	Refer to § 8.13/G.992.3
Short initialization procedures	8.14	O	Short Initialization Sequence shall be optional. If the Short Initialization Sequence is supported, the ADSL modem should also support unbalanced bitswap.

TITLE	ITU-T Rec. G.992.5	CR	Remarks
Loop diagnostics mode procedures	8.15	M	Refer to § 8.15/G.992.3
On-line reconfiguration of the PMD function	8.16	M	Refer to § 8.16/G.992.3
Power management in the PMD function	8.17	M	Refer to § 8.17/G.992.3
<b>Management Protocol Specific Transmission Convergence (MPS-TC) functions</b>	<b>9</b>	GID	
Transport functions	9.1	M	Refer to § 9.1/G.992.3
Additional functions	9.2	M	Refer to § 9.2/G.992.3
Block interface signals and primitives	9.3	M	Refer to § 9.3/G.992.3
Management plane procedures	9.4	M	
Power management	9.5	M	Refer to § 9.5/G.992.3
<b>Dynamic behaviour</b>	<b>10</b>	M	Refer to § 10/G.992.3
<b>Specific requirements for an ADSL system operating in the frequency band above POTS</b>	<b>Annex A</b>	M	ADSL modem shall comply with the ATU-R upstream transmit spectral mask and aggregate transport power specified in A.2/G.992.5. With overlapped spectrum, the widest possible band used is 25.875 to 2208 kHz (i.e., for ADSL over POTS implemented). With non-overlapped spectrum, the widest possible band used is 138 to 2208 kHz.
<b>Specific requirements for an ADSL system operating in the frequency band above ISDN as defined in ITU-T Rec. G.961 Appendices I and II</b>	<b>Annex B</b>	NA	
<b>Specific requirements for an ADSL system operating in the same cable as ISDN as defined in ITU-T Rec. G.961 Appendix III</b>	<b>Annex C</b>	NA	
<b>ATU-C and ATU-R state diagrams</b>	<b>Annex D</b>	GID	Refer to Annex D/G.992.3
<b>POTS and ISDN-BA splitters</b>	<b>Annex E</b>	GID	For operation according to Annexes A, B and I, the G.992.3 requirements applying over a frequency band up to 1104 kHz shall be met over a frequency band up to 2208 kHz.
<b>ATU-x performance requirements for region A (North America)</b>	<b>Annex F</b>	–	Further study by ITU-T
<b>ATU-x performance requirements for region B (Europe)</b>	<b>Annex G</b>	–	Further study by ITU-T
<b>Specific requirements for a synchronized symmetrical DSL (SSDSL) system operating in the same cable binder as ISDN as defined in ITU-T Rec. G.961 Appendix III</b>	<b>Annex H</b>	–	Further study by ITU-T
<b>All digital mode ADSL with improved spectral compatibility with ADSL over POTS</b>	<b>Annex I</b>	O	If applicable, the ADSL modem shall comply with the ATU-R upstream transmit spectral mask and aggregate transport power specified in I.2/G.992.5. With overlapped spectrum, 3 to 2208 kHz is the widest possible band used. With overlapped spectrum, 138 to 2208 kHz is the widest possible band used.

<b>TITLE</b>	<b>ITU-T Rec. G.992.5</b>	<b>CR</b>	<b>Remarks</b>
<b>All Digital Mode ADSL with improved spectral compatibility with ADSL over ISDN</b>	<b>Annex J</b>	NA	
<b>TPS-TC functional descriptions</b>	<b>Annex K</b>	M	Refer to Annex K/G.992.3 and Annex K/G.992.5 for the changes.
–	<b>Annex L</b>	–	Refer to Annex L/G.992.5 Amendment 1 (04/04)
<b>Specific requirements for an ADSL system with extended upstream bandwidth, operating in the frequency band above POTS</b>	<b>Annex M</b>	O	Refer to Annex M/G.992.5 Amendment 1 (04/04) If applicable, the ADSL modem shall comply with the ATU-R upstream transmit spectral mask and aggregate transport power specified in M.2/G.992.5 Amendment 1.
<b>ATM layer to physical layer logical interface</b>	<b>Appendix I</b>	GID	Refer to Appendix I/G.992.3
<b>Compatibility with other customer premises equipment</b>	<b>Appendix II</b>	GID	Refer to Appendix II/G.992.3
<b>The impact of primary protection devices on line balance</b>	<b>Appendix III</b>	GID	Refer to Appendix III/G.992.3
<b>PSD template to be used in capacity calculations with in-band transmit spectrum shaping</b>	<b>Appendix IV</b>	GID	
<b>Bibliography</b>	<b>Appendix V</b>	GID	

## Annex A: Network Specific Implementation Options

Optional Requirements	ITU-T REC. G.992.1 (06/99)	StarHub's Selected Option
ATU-R transmitter reference model for STM bit sync and packet mode transport	5.2.1	Not supported
Transport of STM data	6.1	Not supported
ADSL system overheads and total bit rates b) Reduced overhead	6.3	Supported
STM transmission protocol specific functionalities	8.1	Not supported
Network timing reference	8.3	Not supported
Hyperframe structure	8.4.1.3	Not supported
Subframe structure	8.4.1.4	Not supported
Clear EOC	9.1	Not supported
STM data path related primitives	9.3.2	Not supported
Initialisation with hyperframe (Annex C only)	10.1.5	Not supported
Handshake - ATU-C	10.2	Not supported
Handshake - ATU-R	10.3	Not supported
On-line adaptation - Bit swapping	11.2	Not supported

## Annex B: References

For the technical requirements captured in this Specification, reference has been made to the following documents:

ITU-T Rec. G.992.1 (06/99)	Asymmetric Digital Subscriber Line (ADSL) Transceivers
ITU-T Rec. G.992.2 (06/99)	Splitterless Asymmetric Digital Subscriber Line (ADSL) Transceivers
ITU-T Rec. G.992.3 (07/02)	Asymmetric Digital Subscriber Line Transceivers 2 (ADSL2)
ITU-T Rec. G.992.4 (07/02)	Splitterless Digital Subscriber Line Transceivers 2 (Splitterless ADSL2)
ITU-T Rec. G.992.5 (05/03)	Asymmetric Digital Subscriber Line (ADSL) Transceivers – Extended Bandwidth (ADSL2+)
IEC 60950-1: 2001	Information Technology Equipment – Safety
IEC CISPR 22: 2003-04	Information Technology Equipment – Radio disturbance characteristics – Limits and methods of measurement
IDA TS PSTN (Mar 05)	Technical Specification for Terminal Equipment connected to the Public Switched Telephone Network (PSTN)

## Annex C: Corrigendum/Addendum

Changes to IDA TS ADSL Issue 1 Rev 1 (Apr 06)			
Page	TS Ref.	Items Changed	Effective Date
—	—	Change of IDA's address at cover page to Mapletree Business City.	1 May 11

Changes to IDA TS ADSL Issue 1 (Jul 05)			
Page	TS Ref.	Items Changed	Effective Date
—	—	The Specification has included the technical requirements for the second generation ADSL modems (G.992.3 and G.992.4) as well as for the ADSL 2+ modems (G.992.5).	Apr 06

Changes to IDA TS ADSL 1 and TS ADSL 2			
Page	TS Ref.	Items Changed	Effective Date
—	—	The IDA TS ADSL Issue 1 (Jul 05) has superseded the IDA TS ADSL 1 Issue 1 Rev 1 (Jun 2000) and TS ADSL 2 Issue 1 (Sep 2000).	21 Jul 05
—	—	Title of Specification has been renamed as "Technical Specification for Asymmetric Digital Subscriber Line Modems" (IDA TS ADSL Issue 1).  There are no changes to the technical requirements for the first generation ADSL modems (G.992.1 and G.992.2).	21 Mar 05