



Technical Specification

for connecting to the

Integrated Services Digital Network (ISDN)

using

Basic Access

IDA TS ISDN BA
Issue 1 Rev 1, May 2011

Infocomm Development Authority of Singapore
Resource Management & Standards
10 Pasir Panjang Road
#10-01 Mapletree Business City
Singapore 117438

© Copyright of IDA, 2011

This document may be downloaded from the IDA website at <http://www.ida.gov.sg> and shall not be distributed without written permission from IDA

Contents

		Page
Part A	Introduction	3
1	Scope	3
2	General Requirements	5
3	Electromagnetic Compatibility & Electrical Safety Requirements	6
Part B	Basic User-Network Interface – Layer 1 Specification (ITU-T Rec. I.430 11/1995)	7
Table 1	General layer 1 requirements	7
Table 2	Functional characteristics	7
Table 3	Interface procedures	8
Table 4	Layer 1 maintenance	10
Table 5	Electrical characteristics	10
Table 6	Power feeding	11
Table 7	Interface connector contact assignments	13
Part C	ISDN User-Network Interface – Data Link Layer (ITU-T Rec. Q.921 09/1997 & Amendment 1 06/2000)	14
Table 1	Frame structure for peer-to-peer communication	14
Table 2	Elements of procedure and formats of field for data link layer peer-to-peer communication	14
Table 3	Elements for layer-to-layer communication	15
Table 4	Procedures for use by the data link layer	15
Table 5	Annexes and Appendices	17
Part D	ISDN User-Network Interface Layer 3 Specification for Basic Call Control (ITU-T Rec. Q.931 05/1998 & Amendment 1 12/2002)	18
Table 1	Overview of call control	18
Table 2	Message functional definitions and content	19
Table 3	General message format and information elements coding	20
Table 4	Circuit-switched call control procedures	21
Table 5	List of system parameters	23
Table 6	Packet communication procedures	23
Table 7	User signalling bearer service call control procedures	23
Table 8	Circuit-mode multirate (64 kbit/s base rate) procedures	23
Table 9	Annexes and Appendices	24
Part E	Digital Transmission System on Metallic Local Lines for ISDN Basic Rate Access (ITU-T Recommendation G.961 03/1993)	25
Table 1	Digital transmission system on metallic local lines for ISDN basic rate access	25
Table 2	Core requirements for a system using 2B1Q line code (ITU-T Rec. Q.961 Appendix II)	26
Table 3	Extension functions of the system using 2B1Q line code (Annex A to ITU-T Rec. Q.961 Appendix II)	28
Annex A.1	ISDN Basic Access Implementation Options	29
	Optional Layer 1 Requirements	29
	Optional Layer 2 Requirements	29
	Optional Layer 3 Requirements	29
Annex A.2	Guide to the recognised Information Elements	32
Annex B	References	45
Annex C	Corrigendum / Addendum	46

NOTICE

This Specification is subject to review and revision.

Part A Introduction

1 Scope

- 1.1 This Specification identifies the minimum technical requirements for connecting to the Integrated Services Digital Network (ISDN) at the S/T interface using Basic Access (BA). It also identifies the requirements for the digital transmission system at the network side of the NT1 forming part of the ISDN BA.
- 1.2 ISDN BA equipment connected to the S/T interface (see Figure 1) shall have either the TE1 or TA function incorporated. For such equipment, suppliers shall demonstrate that it has been tested to comply with the requirements defined in Part A, B, C and D of this Specification.
- Part B – Physical layer requirements based on ITU-T Rec. I.430, Basic User-Network Interface – Layer 1 Specification
 - Part C – Link Access Procedure on the D-channel, LAPD based on ITU-T Rec. Q.921, ISDN User-Network Interface – Data Link Layer Specification
 - Part D – Network layer requirements based on ITU-T Rec. Q.931, ISDN User-Network Interface Layer 3 Specification for Basic Call Control
- 1.3 If the ISDN BA equipment has the NT1 function built-in, suppliers shall demonstrate that it has been tested shall to comply with the requirements defined in Part A, B, C, D as well as Part E.
- 1.4 If the NT1 function is standalone, suppliers shall demonstrate that the NT1 equipment has been tested to comply with the requirements defined in Part A and E. Part E defines the digital transmission system at the network side of the NT1, and is based on the ITU-T Rec. G.961. The digital transmission system shall use line codes and transmission methods given in Appendix II of the ITU-T Rec. G.961. References to ETSI ETR 080 are given for information only. The TE side of the NT1 shall conform to the network requirements of the ITU-T Rec. I.430.

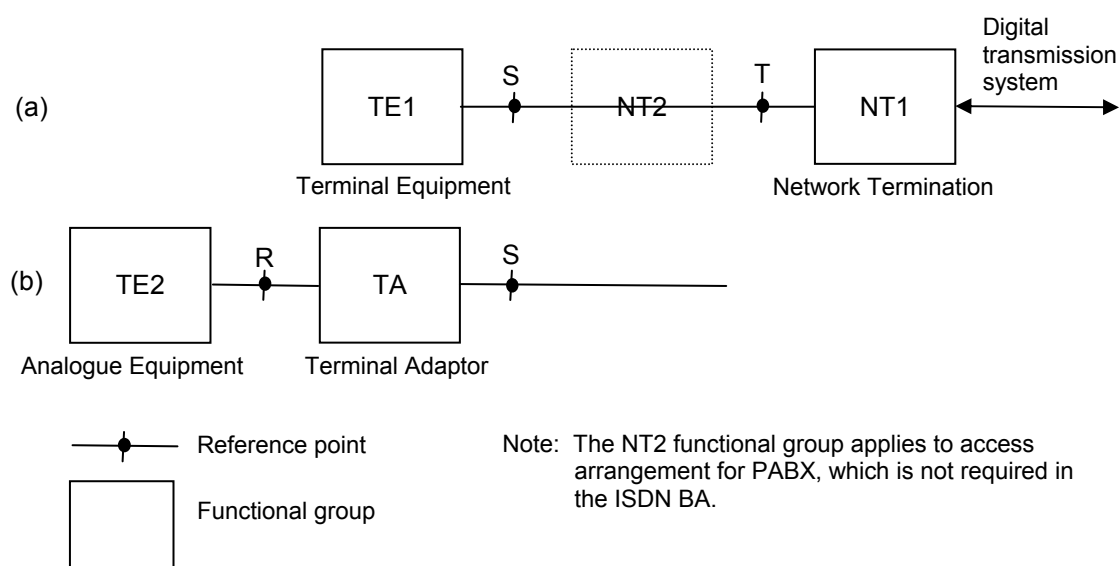

Figure 1: **Reference Configurations for ISDN User-Network Interface** (Figure 1/I.430)

- 1.5 Specific local network implementations are attached as annexes to this Specification where network operators will indicate their selected options for service provision e.g. refer to Annexes A.1 and A.2 for SingTel and StarHub's ISDN implementation options.

1.6 **Notations used in the Specification**

The use of the term TE within the Specification refers to a Terminal Equipment Type 1 (TE1), a Terminal Adaptor (TA) or a Network Termination 2 (NT2).

The following notations are used in the Specification :		
CR		<u>Conformance Requirement</u> defines features and functions that must be supported at minimum.
	M	<u>Mandatory</u> requirement is where the TE implementation shall conform to those clauses in that section relating to the operation of Layer 1, Layer 2 and Layer 3 protocol in the TE.
	O	<u>Optional</u> requirement means it is optional whether TE implements that function but if function is implemented, it shall conform to the clauses in that section relating to the operation of the TE Layer 1, Layer 2 and Layer 3 protocol. However, the use of optional functions is possible only if the network operators have implemented these options in their networks.
	NA	<u>Not Applicable</u> is where the requirements specified in that section on the TE shall not be applicable for attachment.
	GID	The section provides <u>General Information and Definitions</u> .

2 General Requirements

2.1	Design of Equipment	CR
Power supply	A.C. mains supply of 230 V \pm 10%, 50 Hz \pm 2%	Note 1
	External A.C. adapter	Note 1
Identification of equipment	Equipment shall be marked with:	
	(a) supplier's or manufacturer's name or identification mark	M
	(b) supplier's or manufacturer's model or type reference	M
	The markings shall be legible, indelible and readily visible	M
Keypad Dialling	(a) Keypads used in equipment for dialling shall be alphanumeric keypads and the relationships between the letters and the digits shall comply with ITU-T Rec E.161 as shown in figure 1.	M
	(b) The associated letters must not impair the legibility of the digit (§ 3.1.1, ITU-T Rec. E.161).	M
	(c) The tactile identifier on the "5" button shall be provided (§ 3.6, ITU-T Rec. E.161).	M
2.2	Analogue Interface When provided, the equipment has the TA function for connecting analogue equipment at the R interface as shown Figure 2.	–
Connector	2 wire, 6 pin modular RJ 11 jack	Note 2
Feed voltage	\leq 40 V d.c.	Note 2
Line extension	Interworking with loop resistance up to 500 Ω	Note 2
MFPB receiver	(a) Level range: 0 to –26 dBm	Note 2
	(b) Signal detection: min 40 ms	Note 2
	(c) Interdigit pause : min 40 ms	Note 2
	(d) Frequency deviation: \pm 1.8%	Note 2
Ringing current transmit	(a) Frequency: 24 Hz	Note 2
	(b) Periodicity for normal ringing: 0.4 s (on), 0.2 s (off), 0.4 s (on), 2.0 s (off)	Note 2
	(c) Periodicity for duplex/distinctive ringing: 1.2 s (on), 3.0 s (off)	Note 2
	(d) Voltage: \leq 75 V	Note 2
Dial tone transmit	425 Hz continuous tone	Note 2
Busy tone transmit	(a) 425 Hz	Note 2
	(b) Periodicity: 0.75 s (on), 0.75 s (off)	Note 2
Output level	Analogue output signal level shall not exceed –6 dBm averaged over any 10 s period	Note 2
A/D/A companding	Digital telephones and other customer equipment providing acoustic interfaces to the digital bit stream shall comply with ITU-T G.711 (A law).	Note 2
2.3	Characteristics of Telephone	–
SLR	In the range 5 to 11 dB	Note 3
RLR	In the range –1 to 5 dB	Note 3
STMR	In the range 10 to 15 dB	Note 3
<p>Note 1: Either one of these options must be applied.</p> <p>Note 2: Requirement is 'NA' if TE does not have TA function for connecting analogue equipment to the R interface.</p> <p>Note 3: Requirement is 'NA' if TE does not have telephone handset function. If applicable, equipment shall be tested</p>		

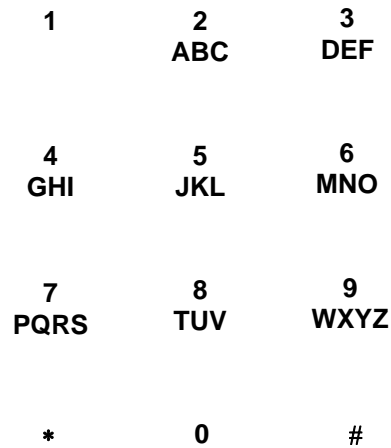

Figure 2: **Alphanumeric Keypad Layout** (ITU-T Rec. E.161)

3 Electromagnetic Compatibility & Electrical Safety Requirements

- 3.1 The equipment shall comply with the limits for conducted disturbance at the mains terminals and telecommunication ports, and the limits for radiated disturbance defined in the IEC CISPR 22.
- 3.2 The equipment shall comply with the IEC 60950-1 safety standard¹. The requirements in IEC 60950-1 that are applicable to the equipment [e.g. class of equipment, type of telecommunication network voltage (TNV) circuit and types of components] shall be identified and complied with.

¹ The safety standard includes, among others, protection of telecommunications network service personnel and users of other equipment connected to the network from hazards in the equipment.

Part B Basic User-Network Interface – Layer 1 Specification

(ITU-T Recommendation I.430 11/1995)

Title	ITU-T Rec. I.430	ETSI TBR 3	CR	Remarks
General	1	–	GID	
Service characteristics	2	–	–	Heading
Services required from the physical medium	2.1	–	M	A balance metallic transmission medium for each direction of transmission capable of supporting 192 kbit/s
Service provided to layer 2	2.2	–	GID	
Primitives between layer 1 and the other entities	2.3	–	GID	
Modes of operation	3	–	GID	
Point-to-point operation	3.1	–	Note 1	
Point-to-multipoint operation	3.2	–	Note 1	
Types of wiring configuration	4	–	GID	
Point-to-point configuration	4.1	–	Note 2	
Point-to-multipoint configuration	4.2	–	Note 2	
Wiring polarity integrity	4.3	–	M	
Location of the interfaces	4.4	–	GID	
NT and TE associated wiring	4.5	–	M	
Note 1: Either one of these modes of operation must be applied.				
Note 2: Either one of these wiring configuration must be applied.				

Title	ITU-T Rec. I.430	ETSI TBR 3	CR	Remarks
Functional characteristics	5	–	GID	Heading
Interface functions	5.1	–	–	Heading
B-channel	5.1.1	–	M	For each direction of transmission, provides two independent 64 kbit/s channels for use as B-channels
Bit timing	5.1.2	–	M	Provides bit timing at 192 kbit/s
Octet timing	5.1.3	–	O	Provides 8 kHz octet timing
Frame alignment	5.1.4	–	M	Provides information to enable NT and TE to recover the TDM channels
D-channel	5.1.5	–	M	For each direction of transmission, provides one D-channel at a bit rate of 16 kbit/s

Table 2: Functional characteristics (continued)				
Title	ITU-T Rec. I.430	ETSI TBR 3	CR	Remarks
D-channel access procedure	5.1.6	–	GID	For procedures relating to D-channel access see clause 6.1.
Power feeding	5.1.7	–	GID	Refer to clause 9
Deactivation	5.1.8	–	GID	Refer to clause 6.2
Activation	5.1.9	–	GID	Refer to clause 6.2
Interchange circuits	5.2	–	M	Two interchange circuits, one for each direction of transmission shall be used to transfer digital signals across the interface.
Connected/disconnected indication	5.3	–	M	The criterion used is the appearance/disappearance of power.
TEs powered across the interface	5.3.1	–	Note 3	
TEs not powered across the interface	5.3.2	–	Note 3	
Indication of connection status	5.3.3	–	M	
Frame structure	5.4	–	M	In both direction of transmission, the bits shall be grouped into frames of 48 bits each.
Line code	5.5	9.3.2	M	Figure 4/I.430
Timing considerations	5.6	–	M	A TE shall derive its timing from the signal received from NT and use this derived timing to synchronise its transmitted signal.
Note 3: Either one of these power arrangements must be applied.				

Table 3: Interface procedures				
Title	ITU-T Rec. I.430	ETSI TBR 3	CR	Remarks
Interface procedures	6	–	–	Heading
D-channel access procedure	6.1	9.4.1	M	
Interframe (layer 2) time fill	6.1.1	9.4.1.1	M	Interframe timefill in the NT to TE direction is HDLC flags.
D-echo channel	6.1.2	–	NA	Network requirement
D-channel monitoring	6.1.3	–	M	
Priority mechanism	6.1.4	9.4.1.2	Note 4	The use of priority class 2 is not a requirement under TBR 3.
Collision detection	6.1.5	9.4.1.3	Note 4	
Priority system	6.1.6	–	GID	An example of how the priority system may be implemented.
Note 4: 'M' for point-to-multipoint configuration, 'NA' for point-to-point.				

Table 3: Interface procedures (continued)				
Title	ITU-T Rec. I.430	ETSI TBR 3	CR	Remarks
Activation/deactivation	6.2	9.4.2	–	Heading
Definitions	6.2.1	–	–	Heading
TE states	6.2.1.1	9.4.2.1	M	PS2 is not a requirement under TBR 3. Loss of local power or absence of power from PS1 may be used for determining the connection status.
NT states	6.2.1.2	–	NA	
Activate primitives	6.2.1.3	–	M	
Deactivate primitives	6.2.1.4	–	M	
Management primitives	6.2.1.5	–	M	
Valid primitive sequences	6.2.1.6	–	NA	
Signals	6.2.2	9.4.2.2	M	
Activation/deactivation procedure for TEs	6.2.3	9.4.2.3	M	
Activation/deactivation for NTs	6.2.4	–	NA	
Timer values	6.2.5	9.4.2.3.2	M	Timer 3 < 30 s
Activation times	6.2.6	–	–	Heading
TE activation times	6.2.6.1	9.4.2.4	M	
NT activation times	6.2.6.2	–	NA	
Deactivation times	6.2.7	9.4.2.5	M	
Frame alignment procedures	6.3	9.4.3	M	
Frame alignment procedure in the direction NT to TE	6.3.1	9.4.3 Note 5	M	Loss of frame alignment is assumed when a time period equivalent to 2 (“n” in the case of TBR 3) 48-bit frames has elapsed without having detected valid pairs of line code violations obeying the ≤ 14-bit criterion as described in § 5.4.2.2. Frame alignment may be assumed to occur when 3 (“m” in the case of TBR 3) consecutive pairs of line code violations obeying the ≤ 14-bit criterion have been detected.
Frame alignment in the direction TE to NT	6.3.2	–	NA	
Multiframeing	6.3.3	9.4.4 Note 6	O	The use of Q-channel and S-channel is optional.
S-channel structuring algorithm	6.3.4	–	O	The use of S-channel is optional.
Idle channel code on the B-channels	6.4	9.4.5	M	
<p>Note 5: In TBR 3, “n” is a value between 2 to 20, and “m” is a value between 3 and 100. There is no requirement for “m” and “n” to remain constant under all circumstances of loss and recovery of frame alignment. The recommended values for “m” and “n” are 5.</p> <p>Note 6: Under TBR 3, when the TE receives an FA bit which is binary ZERO, it shall send a binary ZERO in the corresponding FA bit position of the frame transmitted to the NT. No requirement applies when the FA bit received is a binary ONE.</p>				

Table 4: Layer 1 maintenance				
Title	ITU-T Rec. I.430	ETSI TBR 3	CR	Remarks
Layer 1 maintenance	7	–		Heading
Provision for operational and maintenance functions between terminal and NT1	7.1	–	O	

Table 5: Electrical characteristics				
Title	ITU-T Rec. I.430	ETSI TBR 3	CR	Remarks
Bit rate	8.1	9.2.1	M	192 kbit/s < \pm 100 ppm
Jitter and bit-phase relationship between TE input and output	8.2	9.2.2	–	Heading
Test configurations	8.2.1	9.2.2.1	GID	
Timing extraction jitter	8.2.2	9.2.2.2	M	\pm 7%
Total phase deviation input to output	8.2.3	9.2.2.3 Note 7	M	–7 to +15%
NT jitter characteristics	8.3	–	NA	
Termination of the line	8.4	–	NA	
Transmitter output characteristics	8.5	9.2.3	–	Heading
Transmitter output impedance	8.5.1	–	GID	
NT transmitter output impedance	8.5.1.1	–	NA	
TE transmitter output impedance	8.5.1.2	9.2.3	M	
Test load impedance	8.5.2	–	M	50 Ω
Pulse shape and amplitude (binary ZERO)	8.5.3	9.2.4	M	Figure 13/I.430 750 mV
Pulse unbalance	8.5.4	9.2.5	M	Within the threshold as given in figure 9.5 (TBR 3) / Figure 13/I.430 \leq 5%
Voltage on other test loads (TE only)	8.5.5	9.2.6.1 9.2.6.2	M	400 Ω load and 5.6 Ω load
Unbalance about earth	8.5.6	–	M	10 kHz $\leq f \leq$ 300 kHz : \geq 54 dB 300 kHz < $f \leq$ 1 MHz : min. value decreasing from 54 dB at 20 dB/decade
Longitudinal conversion loss (LCL) of the transmitter output	–	9.2.7	–	10 kHz $\leq f \leq$ 300 kHz : \geq 54 dB
Note 7: The limitation applies for input bit rates of 192 kbit/s \pm 1 ppm.				

Table 5: Electrical characteristics (continued)				
Title	ITU-T Rec. I.430	ETSI TBR 3	CR	Remarks
Receiver input characteristics	8.6	–	–	Heading
Receiver input impedance	8.6.1	–	–	Heading
TE receiver input impedance	8.6.1.1	9.2.8	M	As specified in § 8.5.1.2/I.430
NT receiver input impedance	8.6.1.2	–	NA	
Receiver sensitivity – Noise and distortion immunity	8.6.2	9.2.9	M	
TEs	8.6.2.1	9.2.9	M	
NTs for short passive bus	8.6.2.2	–	NA	
NTs for point-to-point and short passive	8.6.2.3	–	NA	
NTs for extended passive bus	8.6.2.4	–	NA	
NTs for point-to-point configuration	8.6.2.5	–	NA	
NT receiver input delay characteristics	8.6.3	–	NA	
Unbalance about earth	8.6.4	–	M	10 kHz ≤ f ≤ 300 kHz : ≥ 54 dB 300 kHz < f ≤ 1 MHz : min. value decreasing from 54 dB at 20 dB/decade
–	–	9.2.10	–	Longitudinal Conversion Loss (LCL) of receiver inputs 10 kHz ≤ f ≤ 300 kHz : ≥ 54 dB
Isolation from external voltages	8.7	–	GID	
Interconnecting media characteristics	8.8	–	M	
Standard ISDN basic access TE cord	8.9	9.1.4	M	
Longitudinal output voltage	8.10	–	GID	
Electromagnetic compatibility (EMC)	8.11	–	Note 8	
Note 8: EMC requirements are specified in § 3 of this Specification.				

Table 6: Power feeding				
Title	ITU-T Rec. I.430	ETSI TBR 3	CR	Remarks
Power feeding	9	9.5	–	Heading
Reference configuration	9.1	–	M	The use of leads c, d, e and f is mandatory.
Functions specified at the access leads	9.1.1	9.5.1	M	9.1.1 i) is mandatory.
Provision of power sources and sinks	9.1.2	–	O	PS3 is not used.
Power feeding voltage	9.1.3	–	M	Basic voltage range is 34 V to 42 V from the power source.
Power available from NT	9.2	–	–	Heading
Power source 1 normal and restricted mode	9.2.1	–	O	
Voltage NT from power source 1	9.2.2	–	O	
Voltage of power source 2	9.2.3	–	O	
Short circuit protection	9.2.4	–	M	

Table 6: Power feeding (continued)				
Title	ITU-T Rec. I.430	ETSI TBR 3	CR	Remarks
Power available at TE	9.3	–	–	Heading
Power consumption unit	9.3.1	–	GID	
Power source 1 - Phantom powering	9.3.2	9.1.1	O	
Power source 2 - Optional third pair	9.3.3	–	NA	
PS1 current transient	9.4	9.5.2	O	Applicable to TE drawing from power source 1
TE power consumption	9.5	–	–	Heading
Power source 1	9.5.1	9.5.3	O	Applicable when power sink 1 is implemented
Power source 2	9.5.2	– Note 9	O	Applicable when power sink 2 is implemented
Galvanic isolation	9.6	9.5.4 Note 10	O	Isolation shall be a minimum of 1 M Ω when measured at 500 Vd.c.
Limitations on power source and sink during transient condition	9.7	9.5.5	GID	
Current/time limitations for TEs	9.7.1	–	–	Heading
Terminals powered from power source 1	9.7.1.1	9.5.5.1	O	Applicable when power sink 1 is implemented
Terminals powered from power source 2	9.7.1.2	– Note 9	O	Applicable when power sink 2 is implemented
Power source switchover time (PS1 or PS2)	9.7.2	–	O	Applicable when switchover is implemented
Other TE requirements	9.7.3	9.5.5.2	–	Heading
Minimum TE start up current from power source 1	9.7.3.1	9.5.5.2.1	O	Applicable when power sink 1 is implemented
Minimum TE start up current from power source 2	9.7.3.2	– Note 9	O	Applicable when power sink 2 is implemented
Verification	9.7.3.3	–	GID	Test circuit given in clause I.6
Protection against short term interruptions	9.7.3.4	9.5.5.2.2	M	
Behaviour at switch-over	9.7.3.5	9.5.5.2.3	O	Applicable when switch-over is implemented
Effective capacitance at the PS1 or PS2 input to the TE	9.7.3.6	–	GID	
TE behaviour at low input voltage	9.7.3.7	–	GID	
Other power source requirements	9.7.4	–	O	
PS1 direct current unbalance	9.8	–	GID	
TE requirements	9.8.1	9.5.5.3	O	
NT requirements	9.8.2	–	NA	
Additional requirements for an auxiliary power supply (APS)	9.9	–	NA	
Additional requirements for NT1 restricted mode source for compatibility with an APS	9.10	–	NA	
Note 9: Under TBR 3, PS2 is not supported.				
Note 10: Under TBR 3, for galvanic connection to earth, the direct current between PS1 and any earth connection on the TE shall not exceed 100 μ A.				

Table 7: Interface connector contact assignments				
Title	ITU-T Rec. I.430	ETSI TBR 3	CR	Remarks
Interface connector contact assignments	10	9.1 Note 11	M	Contacts a, b, g and h are not used.
Note 11: The use of contacts a, b, g and h for PS2 and PS3 is outside the scope of TBR 3.				

Part C ISDN User-Network Interface – Data Link Layer

(ITU-T Recommendation Q.921 09/1997 & Amendment 1 06/2000)

Title	ITU-T Rec. Q.921	ETSI TBR 3	CR	Remarks
General	1	–	GID	
Frame structure for peer-to-peer communication	2	10.1	–	Heading
General	2.1	10.1.1	M	
Flag sequence	2.2	10.1.2	M	
Address field	2.3	10.1.3	M	
Control field	2.4	10.1.4	M	
Information field	2.5	10.1.5	M	
Transparency	2.6	10.1.6	M	
FCS field	2.7	10.1.7	M	
Format convention	2.8	10.1.8	M	
Invalid frames	2.9	10.1.9 Note 1	M	
Frame abort	2.10	–	M	Not a TBR 3 requirement

Note 1: TBR 3 includes a frame which contains a TEI that is not assigned to the TE as invalid.

Title	ITU-T Rec. Q.921	ETSI TBR 3	CR	Remarks
Elements of procedure and formats of field for data link layer peer-to-peer communication	3	10.2	–	Heading
General	3.1	10.2.1	GID	
Address field format	3.2	10.2.2	M	
Address field variables	3.3	10.2.3	M	
Control field formats	3.4	10.2.4	M	
Control field parameters and associated state variables	3.5	10.2.5	M	
Poll/Final (P/F) bit	3.5.1	10.2.5.1	M	
Multiple frame operation - variables and sequence numbers	3.5.2	10.2.5.2	M	
Unacknowledged operation - variables and parameters	3.5.3	–	GID	One parameter is defined, N201 (see 5.9.3).
Frame types	3.6	10.2.6	–	Heading
Commands and responses	3.6.1	10.2.6.1 Note 1	M	Refer to Table 5/Q.921
Information (I) command	3.6.2	10.2.6.2	M	
Set Asynchronous Balanced Mode Extended (SABME) command	3.6.3	10.2.6.3	M	
Disconnect (DISC) command	3.6.4	10.2.6.4	M	
Unnumbered Information (UI) command	3.6.5	10.2.6.5	M	

Table 2 : Elements of procedure and formats of field for data link layer peer-to-peer communication (continued)				
Title	ITU-T Rec. Q.921	ETSI TBR 3	CR	Remarks
Receive Ready (RR) command/response	3.6.6	10.2.6.6	M	
Reject (REJ) command/response	3.6.7	10.2.6.7	M	
Receive Not Ready (RNR) command/response	3.6.8	10.2.6.8	M	
Unnumbered Acknowledgement (UA) response	3.6.9	10.2.6.9	M	
Disconnected Mode (DM) response	3.6.10	10.2.6.10	M	
Frame Reject (FRMR) response	3.6.11	–	O	Note 1
Exchange Identification (XID) command/response	3.6.12	–	O	Note 1
Note 1: TBR 3 does not support FRMR response and XID command/response				

Table 3 : Elements for layer-to-layer communication				
Title	ITU-T Rec. Q.921	ETSI TBR 3	CR	Remarks
Elements for layer-to-layer communication	4	–	GID	

Table 4 : Procedures for use by the data link layer				
Title	ITU-T Rec. Q.921	ETSI TBR 3	CR	Remarks
Definition of peer-to-peer procedures for the data link layer	5	–	GID	
Procedures for the use of P/F bit	5.1	–	–	Heading
Unacknowledged information transfer	5.1.1	10.4.1	M	
Acknowledged multiple frame information transfer	5.1.2	10.6 and 10.7	M	
Procedure for unacknowledged information transfer	5.2	10.4	M	Note 2
Terminal Endpoint Identifier (TEI) management procedures	5.3	10.5	–	Note 3
General	5.3.1	10.5.1	M	Note 3
TEI assignment procedure	5.3.2	10.5.2	M	Note 3
TEI check procedure	5.3.3	–	–	Heading
Use of TEI check procedure	5.3.3.1	–	NA	
Operation of the TEI check procedure	5.3.3.2	10.5.3	M	Note 4
TEI removal procedure	5.3.4	10.5.4	M	Note 4
TEI identity verify procedure	5.3.5	10.5.5	O	Note 4
Formats and codes	5.3.6	10.5.6	M	Note 4
Initialisation of data link layer parameters	5.4	–	GID	Note 5

Table 4 : Procedures for use by the data link layer (continued)				
Title	ITU-T Rec. Q.921	ETSI TBR 3	CR	Remarks
Procedure for establishment and release of multiple frame operation	5.5	10.6	–	Heading
Establishment of multiple frame operation	5.5.1	10.6.1	M	
Information transfer	5.5.2	10.4, 10.7 and 10.8	M	Refer to clauses 5.2, 5.6 and 5.7
Termination of multiple frame operation	5.5.3	10.6.2	M	
TEI-assigned state	5.5.4	–	M	
Collision of unnumbered commands and responses	5.5.5	10.6.3	M	
Unsolicited DM response and SABME or DISC command	5.5.6	–	M	
Procedure for information transfer in multiple frame operation	5.6	10.7	M	
Re-establishment of multiple frame operation	5.7	10.8	M	
Exception condition reporting and recovery	5.8	10.9 Note 6	M	
List of system parameters	5.9	10.10	GID	
Timer T200	5.9.1	10.10.1	M	The default value shall be 1 s.
Max number of retransmissions (N200)	5.9.2	10.10.2	M	The default value shall be 3.
Max number of octets in an information field (N201)	5.9.3	10.10.3	M	The default value shall be 260 octets.
Max number of transmission of the TEI identity request message (N202)	5.9.4	10.10.4	M	The default value shall be 3.
Max number of outstanding I frames (k)	5.9.5	10.10.5	M	For a SAP supporting basic access signalling, the value is 1.
Timer T201	5.9.6	–	NA	Network requirement
Timer T202	5.9.7	10.10.6	M	The default value shall be 2 s.
Timer T203	5.9.8	–	O	The default value is 10 s.
–	–	10.10.7 Note 7	GID	Layer 2 response time
Data link monitor function	5.10	–	O	

Note 2: 'NA' if TE is an ISPBX and supports configuration using only a single point-to-point data link.

Note 3: 'NA' if TE supports configuration using only a single point-to-point data link. Requirements are applicable if TE is ISPBX.

Note 4: 'NA' if TEI assignment procedure is 'NA'.

Note 5: The data link layer parameters shall be initialised to default values.

Note 6: TBR 3 considers the receipt of an invalid N(R) as the only condition for frame rejection.

Note 7: The maximum time between receipt of an incoming frame, and generation of a response shall not exceed (a) 500 ms if operating in a point-to-point signalling connection; and (b) 200 ms for TEs in point-to-multipoint configuration.

Table 5: Annexes and Appendices				
Title	ITU-T Rec. Q.921	ETSI TBR 3	CR	Remarks
Provision for point-to-point data link connection	Annex A	10.3	O	For single point-to-point signalling connection at layer 3, TEI value 0 shall be used in combination with SAPI 0. TEI management procedures are not applicable.
An SDL representation of the point-to-point procedures of data link layer	Annex B	–	GID	
SDL representation of the broadcast procedures of the data link layer	Annex C	–	GID	
State transition table of the point-to-point procedures of the data link layer	Annex D	–	GID	
Provision of multi-selective reject option	Annex E	–	GID	
Protocol Implementation Conformance Statement (PICS) to Recommendation Q.921 for Basic Rate (User-side)	Annex F	–	GID	
Protocol Implementation Conformance Statement (PICS) to Recommendation Q.921 for Basic Rate (Network-side)	Annex G	–	GID	
Protocol Implementation Conformance Statement (PICS) to Recommendation Q.921 for Primary Rate (User-side)	Annex H	–	NA	
Protocol Implementation Conformance Statement (PICS) to Recommendation Q.921 for Primary Rate (Network-side)	Annex I	–	NA	
Inter-exchange signalling data link layer protocol in Private Integrated Services Networks (PISNs)	Annex J (Q.921 Amendment 1)	–	GID	Applicability and additions to frame structure, elements of procedures, formats of fields, elements for layer-to-layer communication, peer-to-peer procedures to accommodate PISN inter-exchange requirements
Retransmission of REJ response frame	Appendix I	–	O	
Occurrence of MDL-ERROR-INDICATION within the basic states & actions to be taken by the management entity	Appendix II	–	GID	
Optional basic access deactivation procedures	Appendix III	–	NA	May be used by network side system management to control deactivation of access
Automatic negotiation of data link layer parameters	Appendix IV	–	O	
Inter-exchange signalling data link layer protocol in PISNs	Appendix V (Q.921 Amendment 1)	–	GID	Occurrence of the MDL-ERROR indication primitive in the data link layer protocol for the support of Inter-exchange signalling in PISNs

Part D ISDN User-Network Interface Layer 3 Specification for Basic Call Control

(ITU-T Recommendation Q.931 05/1998 & Amendment 1 12/2002)

Table 1: Overview of call control				
Title	ITU-T Rec. Q.931	ETSI TBR 3	CR	Remarks
General	1	–	GID	
Overview of call control	2	–	GID	
Circuit switched calls	2.1	–	GID	
Call states at the user side of the interface	2.1.1	11.1.1	GID	
Null state (U0)	2.1.1.1	11.1.1.1	M	
Call initiated (U1)	2.1.1.2	11.1.1.2	M	
Overlap sending (U2)	2.1.1.3	11.1.1.3	O	Note 1
Outgoing call proceeding (U3)	2.1.1.4	11.1.1.4	M	Note 1
Call delivered (U4)	2.1.1.5	11.1.1.5	M	Note 1
Call present (U6)	2.1.1.6	11.1.1.6	M	Transitory state
Call received (U7)	2.1.1.7	11.1.1.7	O	M if alerting is used
Connect request (U8)	2.1.1.8	11.1.1.8	M	
Incoming call proceeding (U9)	2.1.1.9	11.1.1.9	O	M if call proc. is used
Active (U10)	2.1.1.10	11.1.1.10	M	
Disconnect request (U11)	2.1.1.11	11.1.1.11	M	
Disconnect indication (U12)	2.1.1.12	11.1.1.12	M	
Suspend request (U15)	2.1.1.13	11.1.1.13	O	
Resume request (U17)	2.1.1.14	11.1.1.14	O	
Release request (U19)	2.1.1.15	11.1.1.15	M	
Overlap receiving (U25)	2.1.1.16	11.1.1.16	O	
Call states at the network side of the interface	2.1.2	11.1.2	GID	
Packet mode access connections	2.2	–	O	
Temporary signalling connections	2.3	–	O	
States associated with the global call reference	2.4	11.1.3	O	Note 2
Call states at the user side of the interface	2.4.1	11.1.3.1	GID	
Null (Rest 0)	2.4.1.1	11.1.3.1.1	M	Note 2
Restart request (Rest 1)	2.4.1.2	11.1.3.1.2	O	Note 2
Restart (Rest 2)	2.4.1.3	11.1.3.1.3	M	Note 2
Call states at the network side of the interface	2.4.2	11.1.3.2	NA	
Note 1: TE may not need this call state, but to fulfil procedures specified in ITU-T Rec. Q.931 § 5 and all its subsections, all TEs must implement this call state.				
Note 2: 'NA' if TE supports point-to-multipoint configuration only.				

Table 2 : Message functional definitions and content				
Title	ITU-T Rec. Q.931	ETSI TBR 3	CR	Remarks
Message functional definitions and content	3	11.2	GID	Note 3
Messages for circuit mode connection control	3.1	–	GID	
ALERTING	3.1.1	11.2.1	M	Note 4
CALL PROCEEDING	3.1.2	11.2.2	M	Note 4
CONNECT	3.1.3	11.2.3	M	
CONNECT ACKNOWLEDGE	3.1.4	11.2.4	M	Note 4
DISCONNECT	3.1.5	11.2.5	M	
INFORMATION	3.1.6	11.2.6	O	Note 4
NOTIFY	3.1.7	11.2.7	O	Note 4
PROGRESS	3.1.8	11.2.8	O	Note 4
RELEASE	3.1.9	11.2.9	M	
RELEASE COMPLETE	3.1.10	11.2.10	M	
RESUME	3.1.11	11.2.11	O	Note 5
RESUME ACKNOWLEDGE	3.1.12	11.2.12	O	Note 5
RESUME REJECT	3.1.13	11.2.13	O	Note 5
SETUP	3.1.14	11.2.14	M	
SETUP ACKNOWLEDGE	3.1.15	11.2.15	M	Note 4 - network to user only
STATUS	3.1.16	11.2.16	M	
STATUS ENQUIRY	3.1.17	11.2.17	M	Note 4
SUSPEND	3.1.18	11.2.18	O	Note 5
SUSPEND ACKNOWLEDGE	3.1.19	11.2.19	O	Note 5
SUSPEND REJECT	3.1.20	11.2.20	O	Note 5
Messages for packet mode connection control	3.2	–	O	Note 6
Messages for user signalling bearer service control	3.3	–	O	
Messages used with the global call reference	3.4	11.2.21	–	Heading
RESTART	3.4.1	11.2.21.1	O	Note 7
RESTART ACKNOWLEDGE	3.4.2	11.2.21.2	M	Note 7
STATUS	3.4.3	–	O	Note 7
<p>Note 3: For specific local network implementations (optional messages and information supported by the local networks) refer to the annexes of this Specification.</p> <p>Note 4: It is optional whether a TE ever transmits this message but all TEs must be able to receive the message and handle it correctly as defined in the procedures specified in ITU-T Rec. Q.931 § 5 and all its subsections.</p> <p>Note 5: The support of call re-arrangement is optional. However, if call re-arrangement is implemented then RESUME, RESUME ACKNOWLEDGE, RESUME REJECT, SUSPEND, SUSPEND ACKNOWLEDGE, SUSPEND REJECT messages must be implemented.</p> <p>Note 6: The message shall be used if Case B (packet switched access to an ISDN virtual circuit service) as defined in ITU-T Rec. Q.931 section 6 is implemented.</p> <p>Note 7: 'NA' if TE supports point-to-multipoint configuration only.</p>				

Table 3 : General message format and information elements coding				
Title	ITU-T Rec. Q.931	ETSI TBR 3	CR	Remarks
General message format and information element coding	4	11.3	GID	Note 8
Overview	4.1	11.3.1	M	
Protocol discriminator	4.2	11.3.2	M	
Call reference	4.3	11.3.3	M	
Message type	4.4	11.3.4	M	
Other information elements	4.5	11.3.5	–	Heading
Coding rules	4.5.1	11.3.5.1	M	See Table 4-3/Q.931 Amendment 1
Extensions of codesets	4.5.2	11.3.5.2	O	
Locking shift procedure	4.5.3	11.3.5.3	O	
Non-locking shift procedure	4.5.4	11.3.5.4	O	
Bearer capability	4.5.5	11.3.5.5	M	See Figure 4.11 and Table 4-6/Q.931 Amendment 1
Call identity	4.5.6	11.3.5.6	O	
Call state	4.5.7	11.3.5.7	M	
Called party number	4.5.8	11.3.5.8	M	
Called party subaddress	4.5.9	11.3.5.9	O	
Calling party number	4.5.10	–	O	
Calling party subaddress	4.5.11	–	O	
Cause	4.5.12	11.3.5.10	M	Note 9
Channel identification	4.5.13	11.3.5.11	M	Note 9
Congestion level	4.5.14	–	O	
Date/time	4.5.15	–	O	Note 12
Display	4.5.16	–	O	Note 12
High layer compatibility	4.5.17	11.3.5.12	O	Note 11
Keypad facility	4.5.18	–	O	
Low layer compatibility	4.5.19	11.3.5.13	O	Note 11
More data	4.5.20	–	O	
Network-specific facilities	4.5.21	–	O	
Notification indicator	4.5.22	11.3.5.14	O	
Progress indicator	4.5.23	11.3.5.15	O	Note 9
Repeat indicator	4.5.24	–	O	
Restart indicator	4.5.25	11.3.5.16	O	
Segmented message	4.5.26	–	O	
Sending complete	4.5.27	11.3.5.17	O	Note 10
Signal	4.5.28	–	O	
Transit network selection	4.5.29	–	O	
User to user	4.5.30	–	O	
Information elements for packet communications	4.6	–	O	

Note 8:	For the contents of each information element supported by the local networks, refer to the annexes of this Specification. If optional messages are implemented, the corresponding information elements shall be implemented.
Note 9:	It is optional whether a TE ever transmits this information element but all TEs must be able to receive the information element and handle it correctly as defined in the procedures specified in ITU-T Rec. Q.931 § 5 and all its subsections.
Note 10:	It is optional for a TE to generate this information element, but TEs which implement the Overlap receiving procedure shall recognise the information element and handle it correctly as defined in the procedures specified in ITU-T Rec. Q.931 § 5 and all its subsections.
Note 11:	Support of the HLC/LLC information elements is optional. However, ITU-T Rec. relating to a specific terminal type may require the support to be mandatory for those specific types of terminals.
Note 12:	It is mandatory that the TE recognises the information element but it is optional whether the contents of the information element are displayed.

Table 4 : Circuit-switched call control procedures				
Title	ITU-T Rec. Q.931	ETSI TBR 3	CR	Remarks
Circuit-switched call control procedures	5	–	M	Note 13
Call establishment at originating interface	5.1	11.4.1	M	
Call request	5.1.1	11.4.1.1	M	
B-channel selection - originating	5.1.2	–	M	
Overlap sending	5.1.3	11.4.1.2	O	Note 14
Invalid call information	5.1.4	–	NA	
Call proceeding	5.1.5	11.4.1.3	–	Heading
Call proceeding, enbloc sending	5.1.5.1	11.4.1.3.1	O	
Call proceeding, overlap sending	5.1.5.2	11.4.1.3.2	O	Note 14
Notification of interworking at the originating interface - receipt of - generation of	5.1.6	–	M O	
Call confirmation indication	5.1.7	11.4.1.4	M	
Call connected	5.1.8	11.4.1.5	M	
Call rejection	5.1.9	–	NA	
Transit network selection	5.1.10	–	O	
Call establishment at destination interface	5.2	11.4.2	M	
Incoming call	5.2.1	11.4.2.1	M	
Compatibility checking	5.2.2	11.4.2.2	M	
B-channel selection - destination	5.2.3	11.4.2.3	–	Heading
SETUP message delivered by point-to-point data link	5.2.3.1	11.4.2.3.1	O	Note 15
SETUP message delivered by broadcast data link	5.2.3.2	11.4.2.3.2	O	Note 15
Overlap receiving	5.2.4	11.4.2.4	O	

Table 4 : Circuit-switched call control procedures (continued)				
Title	ITU-T Rec. Q.931	ETSI TBR 3	CR	Remarks
Call confirmation	5.2.5	–	–	Heading
Response to enbloc SETUP or completion of overlap receiving	5.2.5.1	11.4.2.5.1	M	
Receipt of CALL PROCEEDING and ALERTING	5.2.5.2	–	NA	
Called user clearing during incoming call establishment	5.2.5.3	–	NA	
Call failure	5.2.5.4	–	NA	
Notification of interworking at terminating interface - receipt of - generation of	5.2.6	–	M O	
Call accept	5.2.7	11.4.2.6	M	
Active indication	5.2.8	11.4.2.7	M	
Non-selected user clearing	5.2.9	11.4.2.8	M	
Call clearing	5.3	11.4.3	–	Heading
Terminology	5.3.1	11.4.3.1	GID	
Exception conditions	5.3.2	11.4.3.2	M	
Clearing initiated by the user	5.3.3	11.4.3.3	M	
Clearing initiated by the network	5.3.4	11.4.3.4	M	
Clearing when tones/ announcements provided	5.3.4.1	11.4.3.4.1	O	
Clearing when tones/ announcement not provided	5.3.4.2	11.4.3.4.2	O	
Completion of clearing	5.3.4.3	11.4.3.4.3	M	
Clear collision	5.3.5	11.4.3.5	M	
In-band tones and announcements	5.4	–	NA	Refer to network operations
Restart procedure	5.5	11.4.8	M	Note 16
Sending RESTART message	5.5.1	–	O	Note 16
Receipt of RESTART message	5.5.2	–	M	Note 16
Call re-arrangements	5.6	11.4.4	O	Note 17
Call collision	5.7	11.4.5	GID	
Handling of error conditions	5.8	11.4.6	M	
User notification procedure - Receipt of - Generation of	5.9	11.4.7	O	Note 18
Basic telecommunication service identification and selection	5.10	–	O	
Signalling procedures for bearer capability selection	5.11	–	O	
Signalling procedures for high layer compatibility selection	5.12	–	O	
Note 16: 'NA' if TE supports point-to-multipoint configuration only.				
Note 17: The use of call re-arrangement procedure is restricted to basic access, i.e. it will not be available for primary rate access, and is also network implementation dependent.				
Note 18: It is optional whether a TE ever transmits a NOTIFY message but all TEs must be able to receive and handle it correctly as defined in the procedures specified in § 5 and its subsections of ITU-T Rec. Q.931.				

Table 5 : List of system parameters				
Title	ITU-T Rec. Q.931	ETSI TBR 3	CR	Remarks
List of system parameters	9		GID	
Timers in the network side	9.1		NA	
Timers in the user side	9.2	Table F.3	–	Refer to Table 9-2/Q.931
T301			O	Note 19
T302			O	Note 19
T303			O	Note 19
T304			O	Note 19
T305			M	30 s
T308			M	4 s
T309			O	Note 19
T310			O	Note 19
T313			M	4s
T314			O	Note 19
T316			O	Note 19 (2 min)
T317			O	Note 19 (< T316)
T318		–	O	Note 19 (4 s)
T319		–	O	Note 19 (4 s)
T321		–	NA	Note 19
T322		–	O	Note 19 (4 s)
Note 19: Mandatory if the corresponding procedure is implemented, otherwise not applicable.				

Table 6 : Packet communication procedures				
Title	ITU-T Rec. Q.931	ETSI TBR 3	CR	Remarks
Packet communication procedures	6	–	O	Circuit-switched access to PSPDN services (Case A)
			O	Packet switched access to an ISDN virtual circuit service (Case B) using B-channel
			O	Packet switched access to an ISDN virtual circuit service (Case B) using D-channel

Table 7: User signalling bearer service call control procedures				
Title	ITU-T Rec. Q.931	ETSI TBR 3	CR	Remarks
User signalling bearer service call control procedures	7	–	O	

Table 8: Circuit-mode multirate (64 kbit/s base rate) bearer capability				
Title	ITU-T Rec. Q.931	ETSI TBR 3	CR	Remarks
Circuit-mode multirate (64 kbit/s base rate) bearer capability	8	–	O	

Table 9: Annexes and Appendices				
Title	ITU-T Rec. Q.931	ETSI TBR 3	CR	Remarks
User side and network side SDL diagrams	Annex A	–	GID	Note 20
Compatibility and address checking	Annex B	–	M	Note 21
Transit network selection	Annex C	–	O	
Extension for symmetric call operation	Annex D	–	GID	Not applicable to the user-network interface
Network specific facility selection	Annex E	–	O	
D channel backup procedures	Annex F	–	NA	For non-associated signalling applied to multiple primary rate access arrangements only
Use of progress indicators	Annex G	–	M	
Message segmentation procedures	Annex H	–	O	
Low layer information coding principles	Annex I	–	M	
Low layer compatibility negotiation	Annex J	–	O	
Procedure for establishment of bearer connection prior to call acceptance	Annex K	–	O	Network option
Optional procedures for bearer service change	Annex L	–	O	
Additional basic call signalling requirements for the support of private network inter-connection for Virtual Private Network applications	Annex M	–	O	
Flexible channel selection	Annex N	–	O	Network option
Definition of cause values	Appendix I	–	GID	
Example message flow diagrams and example conditions for cause mapping	Appendix II	–	GID	
Signalling for tandem mode operation of Digital Multiplexing Equipment with Low-bit-rate Voice CODEC (DME with LVC)	Appendix III (Q.931 Amendment 1)	–	GID	
Summary of assigned information element identifier and message type code points for the Q.93X – series and Q.95X – series of ITU-T Recommendations	Appendix IV (Q.931 Amendment 1)	–	GID	
<p>Note 20: SDL diagrams are used to describe the Q.931 protocol control for circuit switched basic calls. In the event of conflict, the procedures given in § 5 of Q.931 should take precedence.</p> <p>Note 21: The bearer service requested by the calling user in the Bearer Capability information element shall match the bearer services provided to that user by the network. If a mismatch is detected, the network shall reject the call using one of the causes listed in § 5.1.5.2. At the called side, the user shall be able to support the bearer service offered by the network in the Bearer Capability information element. If a mismatch is detected, the user shall either ignore or reject the offered call using cause number 88, incompatible destination.</p>				

Part E Digital Transmission System on Metallic Local Lines for ISDN Basic Rate Access

(ITU-T Recommendation G.961 03/1993)

Table 1: Digital transmission system on metallic local lines for ISDN basic rate access				
Title	ITU-T Rec. G.961	ETSI ETR 080	CR	Remarks
General	1	1 to 3	GID	
Functions	2	4	M	Bit timing shall be derived from the clock received by the NT1 from LT. 8 kHz octet timing is derived from frame alignment. Remote power feeding is supported.
Transmission Medium	3	5	GID	The transmission medium is the local line distribution network.
System Performance	4	6	GID	
Transmission method	5	7	M	Duplex transmission on 2-wire metallic local lines shall be achieved through the use of Echo Cancellation (ECH).
Activation / Deactivation	6	8	–	Heading
General	6.1	8.1	GID	
Physical representation of signals	6.2	8.2	M	The signals used in the DTS are in accordance with the requirements for a system using 2B1Q line code as given in Appendix II/ G.961.
Operation and Maintenance	7	9	–	Heading
Operation and maintenance functions	7.1	9.1	GID	
C_L channel	7.2	9.2	M	
Power Feeding	8	10	–	Heading
General	8.1	10.1	GID	
Power feeding options	8.2	10.2	M	Power feeding of NT1 (to TE) under normal conditions will be provided by the AC mains power.
			O	A restricted condition will be entered into when AC mains power at the NT1 fails.
Power feeding and recovery methods	8.3	–	GID	
DLL resistance	8.4	10.3	GID	
Wetting current	8.5	10.4	O	The NT1 shall sink a current of at least 200 μ A in its operating voltage range.
LT aspects	8.6	10.5	M	The NT1 shall be able to work with DC input voltages of ≤ 95 V coming from the DLL.
Power requirements of NT1 and regenerator	8.7	10.6	–	Heading
Power requirements of NT1	8.7.1	10.6.1	M	
Power requirements of regenerator	8.7.2	10.6.2	NA	
Current transient limitation	8.8	10.7	M	< 1 mA/ μ s
Environmental Conditions	9	11	GID	

Table 2: Core requirements for a system using 2B1Q line code (ITU-T Rec. Q.961 Appendix II)				
Title	ITU-T Rec. G.961	ETSI ETR 080	CR	Remarks
Line code	II.1	A.1	M	The line code shall be 2B1Q (2 binary, 1 quaternary).
Line baud rate	II.2	A.2	M	The line symbol rate is 80 kbauds.
Clock tolerance	II.2.1	–	–	Heading
NT1 clock tolerance	II.2.1.1	A.2.1	M	± 100 ppm NT1 shall operate with the received signal baud rate in the range of 80 kbaud ± 5 ppm.
LT clock tolerance	II.2.1.2	A.2.2	GID	± 5 ppm
REG clock tolerance	–	A.2.3	GID	
Frame structure	II.3	A.3	M	Figure II.2/G.961
Frame length	II.3.1	A.3.1	M	120 quaternary
Bit allocation in direction LT-NT1	II.3.2	A.3.2	M	Figures II.1/G.961 and II.2/G.961
Bit allocation in direction NT1-LT	II.3.3	A.3.3	M	Figures II.1/G.961 and II.2/G.961
Frame word	II.4	A.4	M	
Frame alignment procedure	II.5	A.5	M	The time limits specified in II.10 shall be met.
Multiframe	II.6	A.6	M	A multiframe is used to enable the allocation of the C _L -channel bits over more than one frame.
Frame offset between LT-NT1 and NT1-LT frames	II.7	A.7	M	Transmitted frames shall be offset with respect to received frames by 60 ± 2 quaternary symbols (i.e. about 0.75 ms).
C_L-channel	II.8	A.8	M	The bit rate for the C _L -channel is 4 kbit/s.
Bit rate	II.8.1	A.8.1	M	
Structure	II.8.2	A.8.2	M	Figure II.3/G.961
Protocol and procedures	II.8.3	A.8.3	M	Figure II.3/G.961
Error monitoring functions	II.8.3.1	A.8.3.1	M	
Other C _L -channel functions	II.8.3.2	A.8.3.2	M	
Far end block error (FEBE) bit. mandatory	II.8.3.2.1	A.8.3.2.1	M	
The ACT bit, mandatory	II.8.3.2.2	A.8.3.2.2	M	
The DEA bit, mandatory	II.8.3.2.3	A.8.3.2.3	M	
NT1 power status bits	II.8.3.2.4	A.8.3.2.4	O	
NT1 test mode indicator (NTM) bit	II.8.3.2.5	A.8.3.2.5	O	
Cold-start-only (CSO) bit	II.8.3.2.6	A.8.3.2.6	O	
DLL-only-activation (UOA) bit	II.8.3.2.7	A.8.3.2.7	O	
S/T-interface-activity-indicator (SAI) bit	II.8.3.2.8	A.8.3.2.8	O	
Alarm indicator bit (AIB)	II.8.3.2.9	A.8.3.2.9	O	
Network indicator bit (NIB) for network use	II.8.3.2.10	A.8.3.2.10	M	The NT1 shall always set this bit to binary ONE in SN3.
Reserved bits	II.8.3.2.11	A.8.3.2.11	M	
Embedded operations channel (EOC) functions	II.8.3.3	A.8.3.3	M	

Table 2: Core requirements for a system using 2B1Q line code (ITU-T Rec. Q.961 Appendix II) (continued)				
Title	ITU-T Rec. G.961	ETSI ETR 080	CR	Remarks
Scrambling	II.9	A.9	M	
Start-up and control	II.10	A.10 Note 1	M	The NT1 shall be able to support both cold-start and warm-start.
Signals used for start-up and control	II.10.1	A.10.1	M	
Timers	II.10.2	A.10.2	M	
Description of the start-up procedure	II.10.3	A.10.3	M	Heading
State transition table for the NT1	II.10.4	A.10.4	M	
State transition table for the LT	II.10.5	A.10.5	GID	
Activation times	II.10.6	A.10.6	M	
Jitter	II.11	A.11	M	
Input signal jitter tolerance	II.11.1	A.11.1	M	Figure II.10/G.961
NT1 output jitter limitations	II.11.2	A.11.2	M	
LT input signal jitter tolerance	II.11.3	A.11.3	GID	
LT output jitter and synchronisation	II.11.4	A.11.4	GID	
Test conditions for jitter measurement	II.11.5	A.11.5	GID	
Transmitter output characteristics of NT1 and LT	II.12	A.12	M	Load impedance of 135 ohms resistive over a frequency band of 0 Hz to 160 kHz
Pulse amplitude	II.12.1	A.12.1	M	2.5 V (Figure II.11/G.961)
Pulse shape	II.12.2	A.12.2	M	The transmitted pulse shall have the shape specified in Figure II.11/G.961. The pulse mask for the four quaternary symbols shall be obtained by multiplying the normalized pulse mask shown in Figure II.11 by 2.5 V, 5/6 V, -5/6 V or -2.5 V.
Signal power	II.12.3	A.12.3	M	Between 13.0 dBm and 14.0 dBm over the frequency band from 0 Hz to 80 kHz
Power spectral density	II.12.4	A.12.4	M	Figure II.12/G.961
Transmitter linearity	II.12.5	A.12.5	M	
Transmitter/receiver termination	II.13	A.13	-	Heading
Impedance	II.13.1	A.13.1	M	135 Ω
Return loss	II.13.2	A.13.2	M	Figure II.14/G.961
Longitudinal conversion loss	II.13.3	A.13.3	M	Figure II.15/G.961
Note 1 The use of cold-start-only transceivers is outside the scope of ETR 080.				

Table 3 : Extension functions of the system using 2B1Q line code (Annex A to ITU-T Rec. Q.961 Appendix II)				
Title	ITU-T Rec. G.961	ETSI ETR 080	CR	Remarks
Introduction	A.II.1	I-1	GID	
NT1 power status bits	A.II.2	I-2	O	
NT1 test mode indicator (NTM) bit	A.II.3	I-3	O	
Cold-start-only (CSO) bit	A.II.4	I-4	O	
DLL-only -activation (UOA) bit	A.II.5	I-5	O	
S/T-interface-activity-indicator (SAI) bit	A.II.6	I-6	O	
Alarm indicator bit (AIB)	A.II.7	I-7	O	
Longitudinal output voltage	A.II.8	–	GID	
NT1 maintenance modes	A.II.9	–	O	
NT1 Quiet Mode	A.II.9.1	–	O	
Insertion Loss Measurement Test	A.II.9.2	–	O	
NT1 Quiet Mode and Insertion Loss Measurement Test trigger signal	A.II.9.3	–	O	
dc signalling format	A.II.9.4	–	O	
Low frequency ac signalling format	A.II.9.5	–	O	

Annex A.1: ISDN Basic Access Implementation Options

Optional Layer 1 Requirements	ITU-T Rec. I.430 11/95	SingTel's Option	StarHub's Option
Point-to-point operation	3.1	Supported	Supported
Point-to-multipoint operation	3.2	Supported	Supported
Point-to-point configuration	4.1	Supported	Supported
Point-to-multipoint configuration	4.2	Supported	Supported
Multiframing	6.3.3	Not supported, M bit set to binary 0	Not supported, M bit set to binary 0
S-channel structuring algorithm	6.3.4	Not supported, S-subchannels set to all binary 0s	Not supported, S-subchannels set to all binary 0s
Layer 1 maintenance	7	The optional functionality of S- and Q-channels is not implemented.	The optional functionality of S- and Q-channels is not implemented.

Optional Layer 2 Requirements	ITU-T Rec. Q.921 09/97	SingTel's Option	StarHub's Option
Frame Reject (FRMR) response	3.6.11	Supported	Supported
Exchange Identification (XID) command/response	3.6.12	Not supported	Not supported
Data link monitor function	5.10	Supported	Supported
Provision for point-to-point data link connection	Annex A	Supported	Supported
Retransmission of REJ response frame	App. I	Not supported	Not supported
Automatic negotiation of data link layer parameters	App. IV	Not supported	Not supported

Optional Layer 3 Requirements	ITU-T Rec. Q.931 05/98	SingTel's Option	StarHub's Option
Overlap sending (U2)	2.1.1.3	Supported	Supported
Call received (U7)	2.1.1.7	Supported	Supported
Incoming call proceeding (U9)	2.1.1.9	Supported	Supported
Suspend request (U15)	2.1.1.13	Supported	Supported
Resume request (U17)	2.1.1.14	Supported	Supported
Overlap receiving (U25)	2.1.1.16	U25 and N25 states are not supported.	U25 and N25 states are not supported.
Packet mode access connections	2.2	Not supported	Not supported
Temporary signalling connections	2.3	Not supported	Not supported
States associated with the global call reference	2.4	Supported	Supported
Restart request (Rest 1)	2.4.1.2	Supported	Supported
INFORMATION	3.1.6	Supported	Supported
NOTIFY	3.1.7	Supported	Supported
PROGRESS	3.1.8	Supported	Supported

Optional Layer 3 Requirements (continued)	ITU-T Rec. Q.931 05/98	SingTel's Option	StarHub's Option
RESUME	3.1.11	Supported	Supported
RESUME ACKNOWLEDGE	3.1.12	Supported	Supported
RESUME REJECT	3.1.13	Supported	Supported
SUSPEND	3.1.18	Supported	Supported
SUSPEND ACKNOWLEDGE	3.1.19	Supported	Supported
SUSPEND REJECT	3.1.20	Supported	Supported
Messages for packet mode connection control	3.2	Not supported	Not supported
Messages for user to user signalling not associated with circuit switched calls	3.3	Not supported	Not supported
RESTART	3.4.1	Supported	Supported
STATUS	3.4.3	Supported	Supported
Extension of codesets	4.5.2	Not supported	Not supported ²
Locking shift procedure	4.5.3	Not supported	Not supported ⁴
Non-locking shift procedure	4.5.4	Not supported	Not supported ⁴
Call identity	4.5.6	Supported	Supported
Called party subaddress	4.5.9	Supported	Supported
Calling party number	4.5.10	Supported	Supported
Calling party subaddress	4.5.11	Supported	Supported
Congestion level	4.5.14	Not supported	Not supported
Date/time	4.5.15	Supported	Supported
Display	4.5.16	Supported	Supported
High layer compatibility	4.5.17	Supported	Supported
Keypad facility	4.5.18	Supported	Supported
Low layer compatibility	4.5.19	Supported	Supported
More data	4.5.20	Not supported	Not supported
Network-specific facilities	4.5.21	Not supported	Not supported
Notification indicator	4.5.22	Supported	Supported
Progress indicator	4.5.23	Supported	Supported
Repeat indicator	4.5.24	Not supported	Not supported
Restart indicator	4.5.25	Supported	Supported
Segmented message	4.5.26	Not supported	Not supported
Sending complete	4.5.27	Supported	Supported
Signal	4.5.28	Supported	Supported
Transit network selection	4.5.29	Not supported	Not supported
User to user	4.5.30	Supported	Supported
Information elements for packet communications	4.6	Not supported	Not supported
Overlap sending	5.1.3	Supported	Supported
Call proceeding, enbloc sending	5.1.5.1	Supported	Supported
Call proceeding, overlap sending	5.1.5.2	Supported	Supported
Transit network selection	5.1.10	Not supported	Not supported

² Locking and non-locking shift information element is recognised by StarHub's ISDN. Information elements that are in Codeset other than 0 will be discarded. Only Codeset 0 is supported.

Optional Layer 3 Requirements (continued)	ITU-T Rec. Q.931 05/98	SingTel's Option	StarHub's Option
SETUP message delivered by point-to-point data link	5.2.3.1	Supported	Supported
SETUP message delivered by broadcast data link	5.2.3.2	Supported	Supported
Overlap receiving	5.2.4	Not supported	Not supported
Clearing when tones/ announcements provided	5.3.4.1	Supported	Supported
Clearing when tones/ announcement not provided	5.3.4.2	Supported	Supported
Restart procedure	5.5	Supported	Supported
Call re-arrangements	5.6	Supported	Supported
User notification procedure	5.9	Supported	Supported
Basic telecommunication service identification and selection	5.10	Not supported	Not supported
Signalling procedures for bearer capability selection	5.11	Not supported	Not supported
Signalling procedures for high layer compatibility selection	5.12	Not supported	Not supported
Packet communication procedures	6	Not supported	Not supported
User signalling bearer service call control procedures	7	Not supported (as Q.931 clause 2.3 is not supported)	Not supported (as Q.931 clause 2.3 is not supported)
Circuit-mode multirate (64 kbit/s base rate bearer capability)	8	Not supported	Not supported
Timers in the user side	9.2	T301, T302, T314 and T321 are not supported. T303, T304, T309, T310, T316, T317, T318, T319 and T322 are supported.	T301, T302, T314 and T321 are not supported. T303, T304, T309, T310, T316, T317, T318, T319 and T322 are supported.
Transit network selection	Annex C	Not supported	Not supported
Network specific facility selection	Annex E	Not supported	Not supported
Message segmentation procedures	Annex H	Not supported	Not supported
Low layer compatibility negotiation	Annex J	Not supported	Not supported
Procedures for establishment of bearer connection prior to call acceptance	Annex K	Not supported	Not supported
Optional procedures for bearer service change	Annex L	Not supported	Not supported
Additional basic call signalling requirements for the support of private network inter-connection for Virtual Private Network applications	Annex M	Not supported	Not supported
Flexible channel selection	Annex N	Not supported	Not supported

Annex A.2: Guide to the recognised Information Elements

Bearer capability (Q.931 clause 4.5.5)

Octet	Field	Value(s) recognised	SingTel's Option	StarHub's Option
3	Extension bit	Last octet	Supported	Supported
	Coding standard	ITU-T standardised coding	Supported	Supported
		ISO/IEC standard	–	–
		National standard	–	–
		Standard defined for the network (either public or private) present on the network side of the interface	–	–
	Information transfer capability	Speech	Supported	Supported
		Unrestricted digital information	Supported	Supported
		Restricted digital information	–	–
		3.1 kHz audio	Supported	Supported
		Unrestricted digital information with tones/announcements	–	–
	Video	–	–	
4	Extension bit	Last octet	Supported	Supported
	Transfer mode	Circuit mode	Supported	Supported
		Packet mode	–	–
	Information transfer rate	This code shall be used for packet mode calls.	–	–
		64 kbit/s	Supported	Supported
		2 x 64 kbit/s	–	–
		384 kbit/s	–	–
		1536 kbit/s	–	–
		1920 kbit/s	–	–
Multirate (64 kbit/s base rate)	–	–		
5	Extension bit	Last octet	Supported	Supported
		Octet continues through the next octet	Supported	Supported
	User information layer 1 protocol	ITU-T standardised rate adaptation V.110/X.30 (Octet 5a is required. Octets 5b, 5c and 5d are optional.)	Supported	Supported
		Rec. G.711 μ -law	–	–
		Rec. G.711 A-law	Supported	Supported
		Rec. G.721 32 kbit/s ADPCM and Rec. I.460	–	–
		Rec. H.221 and H.242	–	–
		Rec. H.223 and H.245	–	–
		Non-CCITT standardized rate adaption.	–	–
		ITU-T standardised rate adaption V.120 (Octets 5a and 5b are required, octets 5c and 5d are optional.)	Supported	Supported
		ITU-T standardised rate adaption X.31 HDLC flag stuffing.	–	–
		Recommendation G.728 [98] LD-CELP	–	–
	Recommendation G.729 [99] CS-ACELP	–	–	

Bearer capability (Q.931 clause 4.5.5 continued)

Octet	Field	Value(s) recognised	SingTel's Option	StarHub's Option
5a (Note 2)	Extension bit	Last octet	Supported	Supported
		Octet continues through the next octet	Supported	Supported
	Synchronous / Asynchronous	Synchronous	Supported	Supported
		Asynchronous	Supported	Supported
	Negotiation	In-band negotiation not possible	Supported	Supported
		In-band negotiation possible	Supported	Supported
User rate	(as specified in Table 4-6/Q.931 on user rate octet 5a)	Supported	Supported	
5b (for V.110 / X.30 rate adaption)	Extension bit	Last octet	Supported	Supported
		Octet continues through the next octet	Supported	Supported
	Intermediate rate	Not used	Supported	Supported
		8 kbit/s	Supported	Supported
		16 kbit/s	Supported	Supported
		32 kbit/s	Supported	Supported
	Network Independent Clock (NIC) on transmission (Tx)	Not required to send data with network independent clock	Supported	Supported
		Required to send data with network independent clock	Supported	Supported
	Network Independent Clock (NIC) on reception (Rx)	Cannot accept data with network independent clock	Supported	Supported
		Can accept data with network independent clock	Supported	Supported
	Flow control on transmission (Tx)	Not required to send data with flow control mechanism	Supported	Supported
		Required to send data with flow control mechanism	Supported	Supported
	Flow control on reception (Rx)	Cannot accept data with flow control mechanism	Supported	Supported
		Can accept data with flow control mechanism	Supported	Supported

Bearer capability (Q.931 clause 4.5.5 continued)

Octet	Field	Value(s) recognised	SingTel's Option	StarHub's Option
5b (V.120 rate adaption)	Rate adaption header / no header	Rate adaption header not included	Supported	Supported
		Rate adaption header included	Supported	Supported
	Multiple frame establishment support in data link	Multiple frame establishment is not supported. Only UI frames are allowed.	Supported	Supported
		Multiple frame establishment supported	Supported	Supported
	Mode of operation	Bit transparent mode of operation	Supported	Supported
		Protocol sensitive mode of operation	Supported	Supported
	Logical Link Identifier (LLI) negotiation	Default, LLI=256 only	Supported	Supported
		Full protocol negotiation (A connection over which protocol negotiation will be executed is indicated in bit 2 of octet 5b.)	Supported	Supported
	Assignor/assignee	Message originator is "Default assignee"	Supported	Supported
		Message originator is "Assignor only"	Supported	Supported
	In-band/out-band negotiation	Negotiation is done with USER INFORMATION messages on a temporary signalling connection	Supported	Supported
		Negotiation is done in-band using logical link zero	Supported	Supported
5c (Note 2)	Extension bit	Last octet	Supported	Supported
		Octet continues through the next octet	Supported	Supported
	Number of stop bits	Not used	Supported	Supported
		1 bit	Supported	Supported
		1.5 bits	Supported	Supported
		2 bits	Supported	Supported
	Number of data bits excluding parity bit if present	Not used	Supported	Supported
		5 bits	Supported	Supported
		7 bits	Supported	Supported
		8 bits	Supported	Supported
	Parity information	Odd	Supported	Supported
		Even	Supported	Supported
		None	Supported	Supported
		Forced to 0	Supported	Supported
Forced to 1		Supported	Supported	
5d (Note 2)	Extension bit	Last octet	Supported	Supported
	Duplex mode	Half duplex	Supported	Supported
		Full duplex	Supported	Supported
	Modem type	Coded according to network specific rules (as specified in Table 4-6/Q.931 on modem type octet 5d)	Supported	Supported
6	Extension bit	Last octet	Supported	Supported
	Layer 2 identification	Layer 2 identification code	Supported	Supported
	User information layer 2 protocol	Rec. Q.921	Supported	Supported
		Rec. X.25, link level	Supported	Supported
LAN logical link control (ISO/IEC 8802-2)		–	–	

Bearer capability (Q.931 clause 4.5.5 continued)

Octet	Field	Value(s) recognised	SingTel's Option	StarHub's Option
7	Extension bit	Last octet	Supported	Supported
	Layer 3 identification	Layer 3 identification code	Supported	Supported
	User information layer 3 protocol	Rec. Q.931	Supported	Supported
		Rec. X.25, packet layer	Supported	Supported
	ISO/IEC TR 9577 (Protocol identification in the network layer)	–	–	

Note 1: This octet is required if octet 4 indicates multirate (64 kbit/s base rate). Otherwise, it shall not be present.

Note 2: This octet may be present if octet 3 indicates *unrestricted digital information* and octet 5 indicates either of the ITU-T standardised rate adaption V.110/X.30 or V.120. It may also be present if octet 3 indicates 3.1 kHz audio and octet 5 indicates G.711.

Note 3: Octet 5a and further octets are transported transparently and are not interpreted by the network.

Call identity (Q.931 clause 4.5.6)

Octet	Field	Value(s) recognised	SingTel's Option	StarHub's Option
3	Call identity information	The information element is coded in IA5 characters and the default maximum length is 10 octets.	Supported	Supported

Call State (Q.931 clause 4.5.7)

Octet	Field	Value(s) recognised	SingTel's Option	StarHub's Option
3	Coding standard	ITU-T standardised coding	Supported	Supported
		ISO/IEC standard	–	–
		National standard	–	–
		Standard defined for the network (either public or private) present on the network side of the interface	–	–
	Call state value	Null	Supported	Supported
		Call initiated	Supported	Supported
		Overlap sending	Supported	Supported
		Outgoing call proceeding	Supported	Supported
		Call delivered	Supported	Supported
		Call present	Supported	Supported
		Call received	Supported	Supported
		Connect request	Supported	Supported
		Incoming call proceeding	Supported	Supported
		Active	Supported	Supported
		Disconnect request	Supported	Supported
		Disconnect indication	Supported	Supported
		Suspend request	Supported	Supported
		Resume request	Supported	Supported
	Release request	Supported	Supported	
Global interface state value	Null	Supported	Supported	
	Restart request	Supported	Supported	
	Restart	Supported	Supported	

Called party number (Q.931 clause 4.5.8)

Octet	Field	Value(s) recognised	SingTel's Option	StarHub's Option
3	Extension bit	Last octet	Supported	Supported
	Type of number (Note 1)	Unknown (Note 2)	Supported	Supported
		International number (Note 3)	Supported	Supported
		National number	Supported	Supported
		Network specific number	–	–
		Subscriber number (Note 3)	Supported	Supported
		Abbreviated number	–	–
		Reserved for extension	–	–
	Numbering plan identification	Unknown (Note 2)	Supported	Supported
		ISDN/telephony numbering plan (Rec. E.164)	Supported	Supported
		Data numbering plan (Rec. X.121)	–	–
		Telex numbering plan (Rec. F.69)	–	–
		National standard numbering plan	–	–
Private numbering plan		–	–	
Reserved for extension	–	–		
4, etc.	Number digits (IA5 characters)	Decimal digits 0 - 9 (The number digits appear in multiple octet 4's in the same order in which they would be entered, that is, the number digit which would be entered first is located in the first octet 4.)	Supported	Supported

Note 1: For the definition of "number", see ITU-T Rec. I.330.

Note 2: The type of number "unknown" is used when the user or the network has no knowledge of the type of number, e.g. international number, national number, etc. In this case the number of digits field is organized according to the network dialling plan; e.g. prefix or escape digits might be present.

Note 3: Prefix or escape digits shall not be included.

Called party subaddress (Q.931 clause 4.5.9)

Octet	Field	Value(s) recognised	SingTel's Option	StarHub's Option
3	Extension bit	Last octet	Supported	–
	Type of subaddress	NSAP(X.213/ISO 8348 AD2)	Supported	–
		User specified	Supported	–
	Odd/even indicator	Even number of address signals	Supported	–
		Odd number of address signals	Supported	–
4, etc.	Subaddress information	The NSAP X.213/ISO 8348 AD2 address shall be formatted as specified by octet 4 which contains the Authority and Format Identifier (AFI). The encoding is made according to the "preferred binary encoding" as defined in NSAP X.213/ISO 8348 AD2. For the definition of this type of subaddress, see Rec. I.334. For user specified subaddress, this field is encoded according to the user specification, subject to a maximum length of 20 octets. When interworking with X.25 networks BCD coding should be applied.	Supported	–

Note - It is recommended that users apply the NSAP subaddress type since this subaddress type allows the use of decimal, binary and IA5 characters in a standardised manner.

Calling party number (Q.931 clause 4.5.10)

Octet	Field	Value(s) recognised	SingTel's Option	StarHub's Option
3	Extension bit	Last octet	Supported	Supported
		octet continues through the next octet	Supported	Supported
	Type of number (Note 1)	Unknown (Note 2)	Supported	Supported
		International number (Note 3)	Supported	Supported
		National number (Note 3)	Supported	Supported
		Network specific number (Note 4)	–	–
		Subscriber number (Note 3)	Supported	Supported
		Abbreviated number (Note 5)	–	–
		Reserved for extension	–	–
	Numbering plan identification	Unknown (Note 2)	Supported	Supported
		ISDN/telephony numbering plan (Rec. E.164)	Supported	Supported
		Data numbering plan (Rec. X.121)	–	–
		Telex numbering plan (Rec. F.69)	–	–
		National standard numbering plan	–	–
Private numbering plan		–	–	
Reserved for extension		–	–	
3a	Extension bit	Last octet	Supported	Supported
		Presentation indicator (If octet 3a is omitted "Presentation allowed" is assumed.)	Supported	Supported
	Screening indicator (If octet 3a is omitted "User-provided, verified and passed" is assumed.)	Presentation restricted	Supported	Supported
		Number not available due to interworking	Supported	Supported
		Reserved	Supported	Supported
		User-provided, not screened	Supported	Supported
	User-provided, verified and passed	User-provided, verified and failed	Supported	Supported
		Network provided	Supported	Supported
4, etc.	Number digits	Decimal digits 0 - 9 (This field is coded with IA5 characters, according to the formats specified in the appropriate numbering / dialling plan.)	Supported	Supported

Note 1: For the definition of "number", see ITU-T Rec. I.330.

Note 2: The type of number "unknown" is used when the user or the network has no knowledge of the type of number, e.g. international number, national number, etc. In this case the number of digits field is organized according to the network dialling plan; e.g. prefix or escape digits might be present.

Note 3: Prefix or escape digits shall not be included.

Note 4: The type of number "network specific number" is used to indicate administration/service number specific to the serving network, e.g. used to access an operator.

Note 5: The support of this code is network dependent. The number provided in this information element presents a shorthand representation of the complete number in the specified numbering plan as supported by the network.

Calling party subaddress (Q.931 clause 4.5.11)

Octet	Field	Value(s) recognised	SingTel's Option	StarHub's Option
3	Extension bit	Last octet	Supported	Supported
	Type of subaddress	NSAP (X.213/ISO 8348 AD2)	Supported	Supported
		User specified	Supported	Supported
	Odd/even indicator (Note 1)	Even number of address signals	Supported	Supported
		Odd number of address signals	Supported	Supported
4, etc.	Subaddress information	<p>The NSAP X.213/ISO 8348 AD2 address shall be formatted as specified by octet 4 which contains the Authority and Format Identifier (AFI). The encoding is made according to the "preferred binary encoding" as defined in NSAP X.213/ISO 8348 AD2. For the definition of this type of subaddress, see Rec. I.334.</p> <p>For user specified subaddress, this field is encoded according to the user specification, subject to a maximum length of 20 octets. When interworking with X.25 networks BCD coding should be applied.</p>	Supported	Supported

Note 1: The odd/even indicator is used when the type of subaddress is "user specified" and the coding is BCD.

Note 2: It is recommended that users apply the NSAP subaddress type since this subaddress type allows the use of decimal, binary and IA5 characters in a standardised manner.

Cause (Q.931 clause 4.5.12)

Octet	Field	Value(s) recognised	SingTel's Option	StarHub's Option
3	Extension bit	Last octet	Supported	Supported
		octet continues through the next octet	Supported	Supported
	Coding standard	ITU-T standardised coding	Supported	Supported
	Location Note : Depending on location of users, the local public network and the remote public network may be the same network.	User	Supported	Supported
		Private network serving the local user	Supported	Supported
		Public network serving the local user	Supported	Supported
		Transit network	Supported	Supported
		Public network serving the remote user	Supported	Supported
		Private network serving the remote user	Supported	Supported
		International network	Supported	Supported
Network beyond interworking point		Supported	Supported	
3a	Extension bit	Last octet	Supported	Supported
	Recommendation	Q.931	Supported	Supported
4	Extension bit	Last octet	Supported	Supported
	Cause value	The cause value is divided in two fields, a class (bits 5 through 7) and a value within the class (bits 1 through 4). The class indicates the general nature of the event. The cause values are defined in Appendix I of Q.931.	Supported	Supported
5	Diagnostics	Diagnostic information is not available for every cause. The inclusion of diagnostics is optional. When available the coding of diagnostic(s) is the same as for the corresponding information element identifier or message type code.	Supported	Supported

Channel identification (Q.931 § 4.5.13)

Octet	Field	Value(s) recognised	SingTel's Option	StarHub's Option
3	Extension bit	Last octet	Supported	Supported
	Interface identifier present (Note 1)	Interface implicitly identified (including the D-channel carrying this information element)	Supported	Supported
		Interface explicitly identified in one or more octets, beginning with octet 3.1	Supported	Supported
	Interface type	Basic interface	Supported	Supported
		Other interface e.g. primary rate interface	–	–
	Preferred / Exclusive (has significance only for B-channel selection)	Indicated channel is preferred	–	–
		Exclusive, only the indicated channel is acceptable	Supported	Supported
	D-channel indicator (has significance in D-channel used)	The channel identified is not the D-channel	Supported	Supported
		The channel identified is the D-channel	Supported	Supported
	Information channel selection	No channel	Supported	Supported
B1 channel		Supported	Supported	
B2 channel		Supported	Supported	
Any channel		Supported	Supported	
3.1*	Extension bit	Octet continues through the next octet	Supported	Supported
	Interface identifier	Binary code assigned to interface at the time of subscription	Supported	Supported
3.2* (Note 2)	Extension bit	Last octet	Supported	Supported
	Coding standard	ITU-T standardised coding	Supported	Supported
		ISO/IEC standard	–	–
		National standard	–	–
		Standard defined for the network (either public or private) present on the network side of the interface	–	–
	Number/Map	Channel is indicated by the number in the following octet	Supported	Supported
		Channel is indicated by the slot map in the following octet(s)	Supported	Supported
	Channel type / Map element type	B-channel units	Supported	Supported
H0-channel units		–	–	
H11-channel units		–	–	
H12-channel units		–	–	
3.3* (Note 2)	Channel number / Slot map	Channel number - Binary number assigned to the channel. For B-channels, the number equals the time slot number.	Supported	Supported

Note 1: When the “interface identifier present” field in octet 3 indicates “interface implicitly identified” octet 3.1 is omitted. When octet 3.1 is present, it may be extended by using the extension bit (bit 8).

Note 2: When the “interface type” field in octet 3 indicates “basic interface”, octets 3.2 and 3.3 are functionally replaced by the “information channel selection” field in octet 3, and thus omitted.

Congestion level (Q.931 clause 4.5.14)

The purpose of the Congestion level information element is to describe the congestion status of the call. It is a single octet information element coded as shown in Figure 4-20/Q.931 and Table 4-14/Q.931.

Congestion level information element is not supported in both SingTel's and StarHub's ISDN.

Date/time (Q.931 clause 4.5.15)

Octet	Field	Value(s) recognised	SingTel's Option	StarHub's Option
3	Year	This field is binary coded.	Supported	Supported
4	Month	This field is binary coded.	Supported	Supported
5	Day	This field is binary coded.	Supported	Supported
6	Hour	This field is binary coded.	Supported	Supported
7	Minute	This field is binary coded.	Supported	Supported
8	Second	This field is binary coded.	–	–

Display (Q.931 clause 4.5.16)

Octet	Field	Value(s) recognised	SingTel's Option	StarHub's Option
3	Display information	The display information element is coded in IA5 characters and has a network dependent default maximum length of 34 or 82 octets.	Supported	Supported

High layer compatibility (Q.931 clause 4.5.17)

The purpose of the High layer compatibility information element is to provide a means, which should be used by the remote user for compatibility checking. See Annex B/Q.931.

The High layer compatibility information element is coded as shown in Figure 4-23/Q.931 and Table 4-15/Q.931.

The maximum length of this information element is five octets.

Note: The high layer compatibility information element is transported transparently by an ISDN between a call originating entity, e.g., a calling user and the addressed entity, e.g., a remote user or a high layer function network node addressed by the call originating entity.

Keypad facility (Q.931 clause 4.5.18)

Octet	Field	Value(s) recognised	SingTel's Option	StarHub's Option
3	Keypad facility information	IA5 characters entered by means of a terminal keypad	Supported	Supported

Low layer compatibility (Q.931 clause 4.5.19)

The purpose of the Low layer compatibility information element is to provide a means to be used for capability checking by an addressed entity (e.g. a remote user or an interworking unit or a high layer function network node addressed by the calling user). The low layer information element is transferred transparently by an ISDN between the call originating entity (e.g., the calling user) and the addressed entity (see Annex B and Annex I).

The Low layer compatibility information element is coded as shown in Figure 4-25/Q.931 and Table 4-16/Q.931. The maximum length of this information element is 18 octets.

More data (Q.931 clause 4.5.20)

The More data information element is sent by the user to the network in a USER INFORMATION message, and delivered by the network to the destination user(s) in the corresponding USER INFORMATION message. The presence of the More data information element indicates to the destination user that another USER INFORMATION message will follow, containing information belonging to the same block.

The network does not supervise the use of the More data information element.

The More data information element is coded as shown in Figure 4-26/Q.931. The length of this information element is one octet.

More data information element is not supported in both SingTel's and StarHub's ISDN.

Network-specific facilities (Q.931 clause 4.5.21)

The purpose of the Network-specific facilities information element is to indicate which network facilities are to be invoked. The Network-specific facilities information element is coded as shown in Figure 4-27/Q.931 and Table 4-18/Q.931. No more than four Network-specific facilities information elements may be included in a single message.

The maximum length of this information element is network dependent.

Network-specific facilities information element is not supported in both SingTel's and StarHub's ISDN.

Notification indicator (Q.931 clause 4.5.22)

Octet	Field	Value(s) recognised	SingTel's Option	StarHub's Option
3	Extension bit	Last octet	Supported	Supported
	Notification description	User suspended	Supported	Supported
		User resumed	Supported	Supported
		Bearer service change	–	–

Progress indicator (Q.931 clause 4.5.23)

Octet	Field	Value(s) recognised	SingTel's Option	StarHub's Option
3	Extension bit	Last octet	Supported	Supported
	Coding standard	ITU-T standardised coding	Supported	Supported
		ISO/IEC standard	–	–
		National standard	–	–
		Standard specific to identified location	–	–
	Location	User	Supported	Supported
		Private network serving the local user	Supported	Supported
		Public network serving the local user	Supported	Supported
		Transit network	Supported	Supported
		Public network serving the remote user	Supported	Supported
Private network serving the remote user		Supported	Supported	
Network beyond the interworking point	Supported	Supported		
4	Extension bit	Last octet	Supported	Supported
	Progress description	Call is not end-to-end ISDN; further call progress information may be available in-band	Supported	Supported
		Destination address is non ISDN	Supported	Supported
		Origination address is non ISDN	Supported	Supported
		Call has returned to the ISDN	Supported	Supported
		Interworking has occurred and has resulted in a telecommunication service change	–	–
		In-band information or an appropriate pattern is now available	Supported	Supported

Repeat indicator (Q.931 clause 4.5.24)

The purpose of the Repeat indicator information element is to indicate how repeated information elements shall be interpreted, when included in a message. The Repeat indicator information element is included before the first occurrence of the information element which will be repeated in a message. The Repeat indication information element is coded as shown in Figure 4-30/Q.931 and Table 4-21/Q.931.

The length of this information element is one octet.

Repeat indicator information element is not supported in both SingTel's and StarHub's ISDN.

Restart indicator (Q.931 clause 4.5.25)

Octet	Field	Value(s) recognised	SingTel's Option	StarHub's Option
3	Extension bit	Last octet	Supported	Supported
	Class	Indicated channels ³	Supported	Supported
		Single interface	–	Supported
		All interfaces	–	Supported

³ In the network to user direction only indicated channel is used. However, the StarHub's ISDN supports all class values from the user to network direction.

Segmented message (Q.931 clause 4.5.26)

The purpose of the Segmented message information element is to indicate that the transmission in which it appears is part of a segmented message, in addition to the use of message type SEGMENT. When included in a message segment, it appears directly after the Message type information element (see Annex H/Q.931).

The Segmented message information element is coded as shown in Figure 4-32/Q.931 and Table 4-23/Q.931. The length of this information element is four octets.

Segmented message information element is not supported in both SingTel's and StarHub's ISDN.

Sending complete (Q.931 clause 4.5.27)

The purpose of the Sending complete information element is to optionally indicate completion of called party number.

It is a single octet information element coded as shown in Figure 4-33/Q.931.

Signal (Q.931 clause 4.5.28)

Octet	Field	Value(s) recognised	SingTel's Option	StarHub's Option
3	Signal value	Convey information to user regarding tones and alerting signals (see clause 7)	Supported	Supported

Transit network selection (Q.931 clause 4.5.29)

The purpose of the Transit network selection information element is to identify one requested transit network. The Transit network selection information element may be repeated in a message to select a sequence of transit networks through which a call must pass (see Annex C/Q.931).

The Transit network selection information element is coded as shown in Figure 4-35/Q.931 and Table 4-25/Q.931. The maximum length of this information element is network dependent.

Transit network selection information element is not supported in both SingTel's and StarHub's ISDN.

User-user (Q.931 clause 4.5.30)

The purpose of the User-user information element is to convey information between ISDN users. This information is not interpreted by the network, but rather is carried transparently and delivered to the remote user(s).

The User-user information element is coded as shown in Figure 4-36/Q.931 and Table 4-26/Q.931. There are no restrictions on content of the user information field.

Annex B: References

For the technical requirements captured in this Specification, reference has been made to the following documents:

ITU-T Rec. I.430 (11/95)	Basic User-Network Interface – Layer 1 Specification
ITU-T Rec. Q.921 (09/97)	ISDN User-Network Interface – Data Link Layer Specification
ITU-T Rec. Q.921 Amendment 1 (02/2000)	ISDN User-Network Interface – Data Link Layer Specification Amendment 1
ITU-T Rec. Q.931 (05/98)	ISDN User-Network Interface Layer 3 Specification for Basic Call Control
ITU-T Rec. Q.931 Amendment 1 (05/98)	ISDN User-Network Interface Layer 3 Specification for Basic Call Control Amendment 1 Extensions for the support of digital multiplexing equipment
Erratum1 (02/2003) to ITU-T Rec. Q.931	ISDN User-Network Interface Layer 3 Specification for Basic Call Control
ITU-T Rec. G.961 03/93	Digital Transmission System on Metallic Local Lines for ISDN Basic Rate Access
ETSI TBR 3 Nov 95	Attachment requirements for terminal equipment to connect to an ISDN using ISDN basic access
ETSI TBR 3 A1 Dec 97	This amendment A1 modifies the TBR 3 (1995)
ETR 080 Nov 96	Digital transmission system on metallic local lines
IEC 60950-1: 2001	Information Technology Equipment – Safety
IEC CISPR 22: 2003-04	Information Technology Equipment – Radio disturbance characteristics – Limits and methods of measurement

Note:

ETSI	European Telecommunications Standards Institute
ETR	ETSI Technical Report
IEC	International Electro-technical Commission
ITU-T	International Telecommunication Union – Telecommunication Sector
TBR	Technical Basis for Regulation

Annex C: Corrigendum / Addendum

Changes to IDA TS ISDN BA Issue 1, Jul 05			
Page	TS Ref.	Items Changed	Effective Date
—	—	Change of IDA's address at cover page to Mapletree Business City.	1 May 11

Changes to IDA TS ISDN 1 Issue 1 Rev 3 & ISDN 3 Issue 1 Rev 3			
Page	TS Ref.	Items Changed	Effective Date
—	—	<p>Title of Specification has been renamed as "Technical Specification for connecting to the Integrated Services Digital Network (ISDN) using Basic Access (BA)" (IDA TS ISDN BA Issue 1).</p> <p>The Technical Specification has superseded the following two IDA Type Approval Specifications:</p> <ul style="list-style-type: none"> (a) IDA TS ISDN 1 Issue 1 Rev 3 (b) IDA TS ISDN 3 Issue 1 Rev 3 <p>The Technical Specification has also incorporated the EMC requirements, previously published under the IDA TS EMC Issue 1 Rev 1.</p> <p>Changes are mainly editorial in nature, in which the essential technical requirements for compliance formerly defined under the two Specifications (TS ISDN 1 and TS ISDN 3) are now incorporated as one.</p>	21 Jul 05