



## **Technical Specification**

for

## **Terminal Equipment**

connecting to the

## **Public Switched Telephone Network (PSTN)**

### **IDA TS PSTN**

Issue 1 Rev 2, May 2011

Infocomm Development Authority of Singapore  
Resource Management & Standards  
10 Pasir Panjang Road  
#10-01 Mapletree Business City  
Singapore 117438

© Copyright of IDA, 2011

This document may be downloaded from the IDA website at <http://www.ida.gov.sg> and shall not be distributed without written permission from IDA

## Contents

	<b>Page</b>	
1	Scope	3
2	General Requirements	3
3	Electromagnetic Compatibility & Electrical Safety Requirements	3
4	Method of Connection	4
5	General Operating Requirements	5
6	Electrical Characteristics	6
7	Calling Function	7
8	Automatic Answering	10
<b>Annex</b>		
A	Analogue Handset Function	11
B	2-Wire Analogue Leased Line Requirements	12
C	Call Detail Recording Facilities	14
D	Cordless Telephone Facility	15
E	Requirements for Coinafon	16
F	Requirements for Credit Card, Phonecard, ATM Card, Cashcard and Multi-Coin Payphone	18
G	Requirements for Caller Identity Equipment	22
H	Requirements for Call Switching Equipment	25
I	Requirements for Direct Inward Dialling	26
J	Input Procedure for Sending Alphanumeric Characters	32
K	Requirements for Short Message Service (SMS)	33
L	Requirements for POTS Splitter / Line Filters for use with ADSL Services	34
M	References	35
N	Addendum/Corrigendum Changes to IDA TS PSTN Issue 1 Rev 1, Mar 07 Changes to IDA TS PSTN Issue 1 Changes to IDA TS PSTN 1 Issue 4 Rev 2	36

<b>NOTICE</b>
---------------

<b>This Specification is subject to review and revision.</b>
--

## 1 Scope

- 1.1** This Specification is applicable to all types of terminal equipment (TE) that can be approved for connection to the Public Switched Telephone Network (PSTN).
- 1.2** The technical requirements specified are intended to cover:
- (a) the protection of users and personnel operating the network from hazards that may arise from the connection of terminal equipment to public telecommunication network (section 3);
  - (b) the protection of public telecommunication network and service from interference and other adverse effects (sections 3, 5 to 8); and
  - (c) the assessment of compatibility of the terminal equipment with the network (sections 4 to 8).
- 1.3** Additional requirements are included as annexes to the Specification They are applicable to the optional facilities supported by the different network operators.

## 2 General Requirements

### 2.1 Power Supply

- 2.1.1** The TE may be a.c. powered or d.c. powered. For an a.c. powered equipment, the technical requirements shall be complied with when operating from an a.c. mains supply of voltage,  $230V \pm 10\%$  and frequency,  $50 \text{ Hz} \pm 2\%$ . Where external power supply is used, e.g. AC adaptor, it shall not affect the capability of the TE to meet the technical requirements.
- 2.1.2** Certain equipment may be allowed to be powered by d.c. from the exchange battery. In such cases, the current drawn by the equipment in the unlooped condition shall not be greater than 2 mA.

### 2.2 Polarity

The performance of the terminal equipment shall be independent of the line polarity i.e. the TE shall conform to the requirements of this Specification for both polarities of the line feeding (ETSI TBR 21, clause 4.3.1).

### 2.3 Identification of Equipment

The TE shall be marked with the supplier's or manufacturer's name or identification mark, and the supplier's or manufacturer's model or type reference. The markings required shall be legible, indelible and readily visible.

## 3 Electromagnetic Compatibility & Electrical Safety Requirements

- 3.1** The equipment shall comply with the limits for conducted disturbance at the mains terminals and telecommunication ports, and the limits for radiated disturbance defined in the IEC CISPR 22.
- 3.2** The equipment shall comply with the IEC 60950-1 safety standard<sup>1</sup>. The requirements in IEC 60950-1 that are applicable to the equipment [e.g. class of equipment, type of telecommunication network voltage (TNV) circuit and types of components] shall be identified and complied with.

---

<sup>1</sup> The safety standard includes, among others, protection of telecommunications network service personnel and users of other equipment connected to the network from hazards in the equipment.

**Note:**

The following notations are used in the Specification:

- CR Conformance requirement defines features and functions which must be supported at minimum.
- M Mandatory requirements
- O Optional requirements
- NA Not Applicable
- GID General Information and Definitions

## 4 Method of Connection

4.1	Public Telecommunication Network Termination	CR	Remarks
	Public telecommunication network termination for the connection of the TE is a miniature 6-position socket shown in Figure 1.	GID	
4.1.1	Connection of the TE to the public telecommunication network termination is in accordance with Figure 1(a).	O	
4.1.2	Connection of the TE to the public telecommunication network termination is in accordance with Figure 1(b).	O	

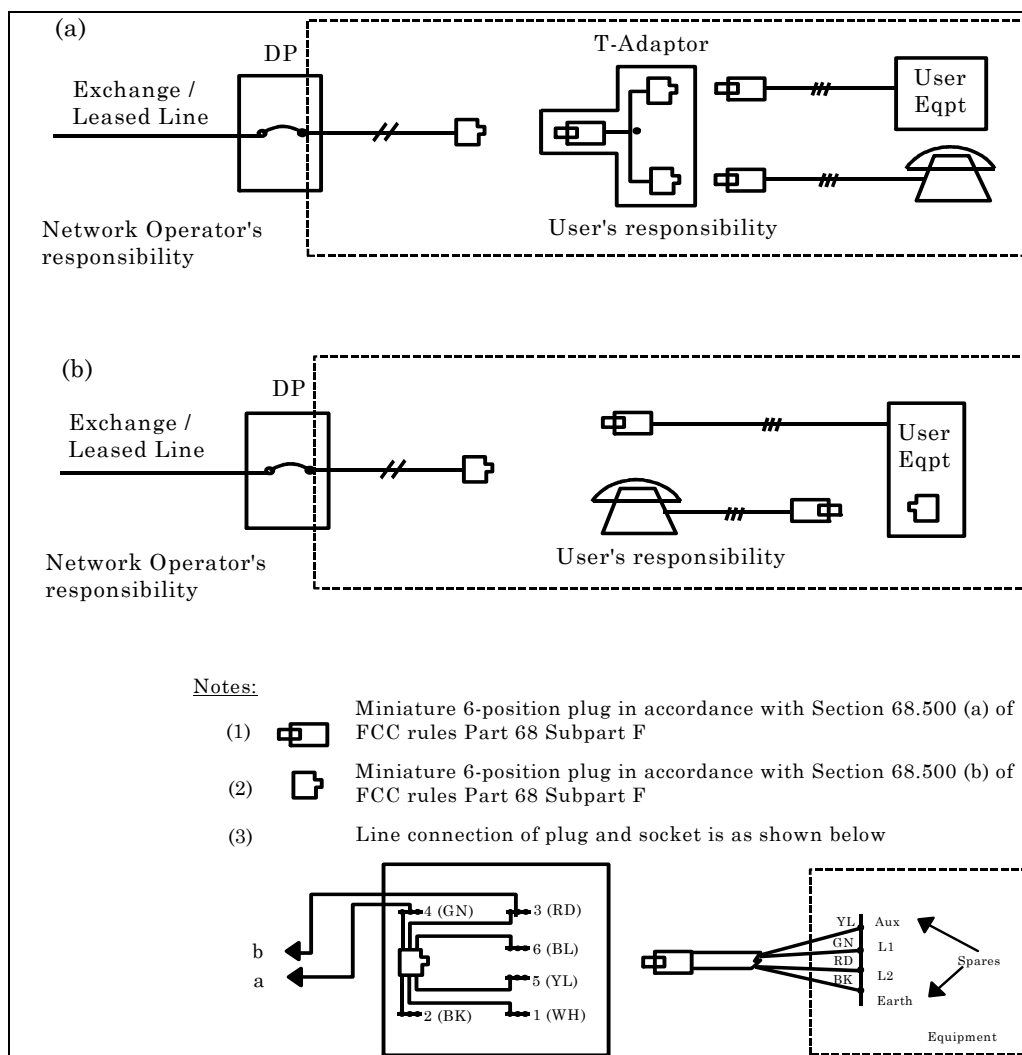

**Figure 1: Methods of connection**

## 5 General Operating Requirements

5.1	Ringling Signal and Service Tones	CR	Remarks
5.1.1	TE shall be able to work with the ringing signal from the public exchange as given in Table 1.	M	
5.1.2	TE shall be able to work with the service tones from the public exchange as shown in Table 1.	M	

5.2	Power-Fail Condition	CR	Remarks
5.2.1	In the event of failure of the power supply (back up supply included), the unattended TE shall immediately release the exchange line(s) and place it (them) in unlooped condition.	M	
5.2.2	Upon the restoration of power, the TE shall remain in the unlooped condition when not in use.	M	

**Table 1: Ringling Signal and Service Tones in the Public Switched Telephone Network (PSTN)**

Tone No.	Ringling Signal and Service Tones	Frequency (Hz)	Level at exchange MDF *	Periodicity
	Ringling Current	24	75 V nominal	0.4 s on 0.2 s off 0.4 s on 2.0 s off
1	Dial Tone	425	-15 dBm	Continuous
2	Ringling Tone	425 x 24	-10 dBm	0.4 s on 0.2 s off 0.4 s on 2.0 s off
3	Busy Tone	425	-10 dBm	0.75 s on 0.75 s off
4	NU Tone	425	-10 dBm	2.5 s on 0.5 s off
5	Congestion Tone	425	-10 dBm	0.25 s on 0.25 s off
6	Intrusion Tone	425	-20 dBm	0.25 s on 2.0 s off
7	Acceptance Tone	425	-15 dBm	0.125s on 0.125s off
8A	Holding Tone A followed by	425 x 24	-15 dBm	0.5 s on 0.5 s off
8B	Holding Tone B	425	-15 dBm	0.5 s on 2.5 s off
9	Call Waiting Tone	425 x 24	-15 dBm	0.3 s on 0.2 s off 0.3 s on 3.2 s off
10	Special Information Tone (not in use)	950 : 1400 : 1800	-10 dBm	0.33 s : 0.33 s : 0.33 s on 1.0 s off
11	End of Period Tone (Warning Tone)	425	-20 dBm	0.624 s on 4.376 s off
12	Stutter Dial Tone	425	-15 dBm	0.2 on 0.2 off 0.6 on 0.2 off 4 cycles followed by continuous tone

Notes:

1  $f_1 \times f_2 = f_1$  modulated by  $f_2$ , depth of modulation is 100%  
 $f_1 : f_2 = f_1$  followed by  $f_2$

2 The maximum frequency deviation is as follows:

- (a) 425 Hz  $\pm$  20 Hz
- (b) 24 Hz  $\pm$  2 Hz
- (c) Special Information Tone:  $\pm$  50 Hz

\* Nominal values are given. The actual values may deviate from these in working exchanges.

## 6 Electrical Characteristics

6.1	Insulation Resistance	CR	Remarks
	The insulation resistance between any one of the line terminals and the earth terminal shall be $> 5 \text{ M}\Omega$ measured at 100 V d.c.	M	

6.2	Impedance Limits	CR	Remarks
6.2.1	Unlooped Condition	–	Heading
6.2.1.1	TE shall present to the exchange line a d.c. resistance $> 1 \text{ M}\Omega$ measured at 100 V d.c.	M	Acceptable test method: ETSI TBR 21, A.4.4.1
6.2.1.2	TE shall present to the exchange line impedance, $Z > 6.66 \text{ k}\Omega$ in the frequency range of 300 to 3400 Hz, if no additional loading from parallel connections is intended. $Z$ shall be $> 20 \text{ k}\Omega$ in the frequency range of 300 to 3400 Hz if additional loading from parallel connections is intended.	M	Acceptable test method: ETS 300 001, A.4.1.1
6.2.1.3	TE shall present to the exchange line an impedance $> 2 \text{ k}\Omega$ at 24 Hz.	M	Acceptable test method: ETS 300 001, A.4.4.2.1
6.2.1.4	TE shall be able to withstand sustained ringing voltages from the telephone line of 85 V r.m.s. at nominal frequency of 24 Hz.	M	
6.2.2	Looped Condition	–	Heading
6.2.2.1	A d.c. resistance of $80 \Omega$ to $450 \Omega$ for line currents between 20 mA to 110 mA.	M	Acceptable test method: ETSI TBR 21, A.4.7.1
6.2.2.2	For analogue TE supporting non-voice services only, the return loss calculated shall be $> 8 \text{ dB}$ with respect to $600\Omega$ in the frequency range of 300 to 3400 Hz for line current up to 110 mA.	M Note 1	Acceptable test method: ETSI TBR 21, A.4.7.2
6.2.2.3	For analogue TE supporting handset telephony, the return loss calculated shall be $> 14 \text{ dB}$ with respect to $600 \Omega$ in the frequency range of 300 to 3400 Hz for line current up to 110 mA.	O Note 2	Acceptable test method: ETSI TBR 38, A.2.8
6.2.2.4	The equipment shall be capable of performing satisfactorily with continuous d.c. current between 20 mA and 110 mA from the public exchange.	M	Acceptable test method: ETSI TBR 21, A.4.7.1
6.2.3	In the case where the connection of the equipment introduces a resistance in series with PSTN and other terminal equipment, the additional resistance introduced shall be less than $50 \Omega$ .	M	Acceptable test method: ETS 300 001, A.2.5

6.3	Impedance Unbalance about Earth	CR	Remarks
	Impedance unbalance about earth expressed in Longitudinal Conversion Loss (LCL) shall be $\geq 40 \text{ dB}$ in the frequency range of 300 to 600 Hz and $\geq 46 \text{ dB}$ in the frequency range of 600 to 3400 Hz.	M	Acceptable test method: ETSI TBR 21, A.4.7.4

6.4	Signal Frequencies and Sending Levels	CR	Remarks
6.4.1	All signals transmitted to public telecommunication network line shall be nominally confined to the frequency range of 300 to 3400 Hz and the power level during any 10 second period shall not exceed $-6$ dBm when measured with $600 \Omega$ termination.	M Note 3	Acceptable test method: ETSI TBR 21, A.4.7.3.1
6.4.2	Any power transmitted above 3400 Hz shall be reduced progressively by at least 12 dB/octave.	M	Acceptable test method: ETSI TBR 21, A.4.7.3.4
6.4.3	Any individual spectral component of the transmitted signals into the public telecommunication network line shall not exceed $-33$ dBm at frequencies above 3.4 kHz and $-70$ dBm at 50 kHz and above.	M	Acceptable test method: ETSI TBR 21, A.4.7.3.4
Note 1	Requirements are applicable only to non-voice TE (without handset function) such as modems and some facsimile machines.		
Note 2	Requirement is mandatory if TE incorporates analogue handset function.		
Note 3	These requirements do not apply to MFPB (DTMF) signals.		

## 7 CALLING FUNCTION

TE that initiates calls to the public telephone exchange shall conform to the requirements of this section.

7.1	Line Signalling	CR	Remarks																														
	Each originating call shall begin with the establishment of looped condition. The TE shall be able to interwork with the d.c. loop start line signalling method of the public exchange as shown in Tables 2 and 3.	M																															
7.2	Multifrequency Push-Button (MFPB or DTMF) signalling	CR	Remarks																														
7.2.1	The equipment shall send the call address information to the public exchange by means of MFPB signalling codes as specified below. <table border="1" data-bbox="304 1352 858 1581"> <thead> <tr> <th colspan="2"></th> <th colspan="3">Digit Codes</th> </tr> </thead> <tbody> <tr> <td></td> <td>697</td> <td>1</td> <td>2</td> <td>3</td> </tr> <tr> <td></td> <td>770</td> <td>4</td> <td>5</td> <td>6</td> </tr> <tr> <td></td> <td>852</td> <td>7</td> <td>8</td> <td>9</td> </tr> <tr> <td></td> <td>941</td> <td>*</td> <td>0</td> <td>#</td> </tr> <tr> <td></td> <td></td> <td>1209</td> <td>1336</td> <td>1477</td> </tr> </tbody> </table>			Digit Codes				697	1	2	3		770	4	5	6		852	7	8	9		941	*	0	#			1209	1336	1477	M	Acceptable test method: ETSI TBR 21, A.4.8.2.1
		Digit Codes																															
	697	1	2	3																													
	770	4	5	6																													
	852	7	8	9																													
	941	*	0	#																													
		1209	1336	1477																													
7.2.2	Transmit signalling frequencies shall not deviate more than $\pm 1.5\%$ from the nominal values.	M	Acceptable test method: ETSI TBR 21, A.4.8.2.2																														
7.2.3	The sending level for low group frequencies into public telecommunication network line shall be $-8 \pm 2$ dBm.	M	Acceptable test method: ETSI TBR 21, A.4.8.2.2																														
7.2.4	The sending level for high group frequencies into public telecommunication network line shall be $-6 \pm 2$ dBm.	M	Acceptable test method: ETSI TBR 21, A.4.8.2.2																														
	The total power of unwanted frequency components during signalling shall be at least 20 dB below the power level of signal frequency.	M	Acceptable test method: ETSI TBR 21, A.4.8.2.3																														

<b>7.3</b>	<b>Keypad Dialling</b>	<b>CR</b>	<b>Remarks</b>
7.3.1	Keypads used in equipment for dialling shall be alphanumeric keypads and the relationships between the letters and the digits shall comply with ITU-T Rec. E.161 as shown in figure 2.	M	
7.3.2	The associated letters must not impair the legibility of the digit (§ 3.1.1, ITU-T Rec. E.161).	M	
7.3.3	The tactile identifier on the "5" button shall be provided (§ 3.6, ITU-T Rec. E.161)	M	
<b>7.4</b>	<b>Automatic Dialling</b>	<b>CR</b>	<b>Remarks</b>
	For equipment which carries out dialling automatically, (a) the sending length of the MFPB signal shall be at least 65 ms, and (b) the inter-digit pause between 2 MFPB signals shall not be less than 65 ms.	M	Acceptable test method: ETSI TBR 21, A.4.8.2.4 & A.4.8.2.5
<b>7.5</b>	<b>Repeat Call Attempts</b>	<b>CR</b>	<b>Remarks</b>
	For TE with automatic repeat dialling facility, every automatic redial operation shall be limited to a maximum of 10 call re-attempts with intervals of minimum 60 seconds between re-attempts.	M	
<b>7.6</b>	<b>Automatic Calling</b>	<b>CR</b>	<b>Remarks</b>
	Where automatic calling facility is provided in the equipment: (a) a dial tone detector shall be incorporated; (b) dialling digits shall be sent within 5 s of detecting the exchange dial tone.	M	

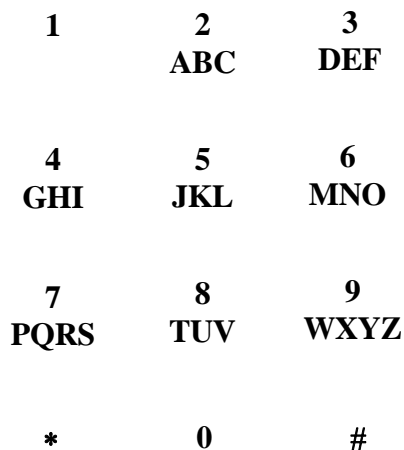

**Figure 2: Alphanumeric Keypad Layout (ITU-T Rec. E.161)**

Table 2: Subscriber Line Conditions for Originating Call

Signal State	Condition at the terminal equipment (Calling Subscriber)		Line Condition at exchange	Remarks
Idle	H		N	
Seizure	H to L	Dial Tone	N	Loop via subscriber terminal equipment
MFPB signalling	L		N	
Ringing	L	Ringing Tone	N	
Answer	L		N or N to R (*2)	
Conversation	L		N or R	
Register recall hooking (*1)	L to H to L		N or R	Loop break (*3)
Calling subscriber clears first (at any state)	L to H		N or R to N	Break in subscriber loop and return to idle state
Called subscriber clears before calling subscriber clears (line lock-out)	L	Busy Tone	N or R	
			Time supervision	Line lock-out condition after time supervision
Calling subscriber subsequently clears	L to H		N or R to N	

Legend: H = High ohmic unlooped state + ve = 0 V and - ve = - 48 V  $\pm$  5 V  
L = Low ohmic looped state  
N = Battery feed with a lead - ve and b lead + ve  
R = Battery feed with a lead + ve and b lead - ve

## Notes:

- (\*1) Register recall is only applicable to subscriber line that has services such as 3 way calling, call waiting service or malicious call tracing.  
(\*2) Line reversal may be sent as answer signal depending on the category of calling subscriber and type of call. For lines requiring a reversal of line potentials as an answer signal for proper working, such facility can be arranged.  
(\*3) Loop break is at a value of 600  $\pm$  300 ms.

**Table 3: Subscriber Line Conditions for Terminating Call**

Signal State	Line Condition at Terminating Exchange	Condition at the terminal equipment (Called Subscriber)		Remarks
Idle	N		H	
Ringing	N	Ringing Current	H	Ringing current on A lead
Answer	N		H to L	
Conversation	N		L	
Register recall hooking (*1)	N		L to H to L	Loop break (*2)
Called subscriber clears first	N		L to H	Return to idle after expiry of time supervision or after calling subscriber clears
Calling subscriber clears before called subscriber clears (line lock-out)	N	Busy Tone	L	
Called subscriber subsequently clears	N		L to H	Return to idle condition

Legend: H = High ohmic unlooped state + ve = 0 V and – ve = – 48 V ± 5 V  
 L = Low ohmic looped state  
 N = Battery feed with a lead – ve and b lead + ve  
 R = Battery feed with a lead + ve and b lead – ve

Notes:

- (\*1) Register recall is only applicable to subscriber line that has services such as 3 way calling, call waiting service or malicious call tracing.  
 (\*2) Loop break is at a value of 600 ± 300 ms.

## 8 Automatic Answering

8	Automatic Answering	CR	Remarks
8.1	TE shall have a ringing signal detector and answer an incoming call by looping the line within 9 seconds from the start of the ringing signal.	Note 1	
8.2	The maximum duration of looped condition for the automatic transmission of prerecorded message shall not exceed 2 minutes.	Note 1	
8.3	The maximum duration of looped condition for the automatic recording of incoming message shall not exceed 30 minutes.	Note 1	
8.4	TE shall restore the exchange line to unlooped condition:  (a) after the detection of busy tone sent by the exchange to indicate that the calling party has cleared first; or (b) alternatively, for equipment with a timer, after the time pre-set for the automatic transmission or recording of message.	Note 1	
Note 1: Requirement is 'M' if TE incorporates features with telephone answering capability e.g. Direct Inward System Access (DISA), voice message system etc.			

## Annex A: Analogue Handset Function

If TE supports handset telephony, then the following additional requirements are applicable.

A.1	Sending and Receiving Loudness Ratings (SLR and RLR)	CR	Remarks
A.1.1	<p>The SLR shall be <math>+3 \text{ dB} \pm 4 \text{ dB}</math> when measured with the feed resistance <math>R_f</math> set to <math>2800 \Omega</math> and <math>1000 \Omega</math> and <math>+3 \text{ dB} +7/-4 \text{ dB}</math> when measured with the feed resistance <math>R_f</math> set to <math>500 \Omega</math>.</p> <p>For TE supporting handsfree or loudspeaking functions which is not powered from a separate power supply, the requirement to measure with <math>R_f</math> set to <math>2800 \Omega</math> shall be replaced by a requirement to measure with <math>R_f</math> set to <math>2300 \Omega</math>.</p>	M	Acceptable test method: ETSI TBR 38, A.2.2.1
A.1.2	<p>The RLR shall be <math>-8 \text{ dB} \pm 4 \text{ dB}</math> when measured with the feed resistance <math>R_f</math> set to <math>2800 \Omega</math> and <math>1000 \Omega</math> and <math>-8 \text{ dB} +7/-4 \text{ dB}</math> when measured with the feed resistance <math>R_f</math> set to <math>500 \Omega</math>.</p> <p>For TE supporting handsfree or loudspeaking functions which is not powered from a separate power supply, the requirement to measure with <math>R_f</math> set to <math>2800 \Omega</math> shall be replaced by a requirement to measure with <math>R_f</math> set to <math>2300 \Omega</math>.</p>	M	Acceptable test method: ETSI TBR 38, A.2.2.2
A.2	Sidetone	CR	Remarks
	Sidetone Masking Rating (STMR) shall not be less than $+10 \text{ dB}$ .	M	Acceptable test method: ETSI TBR 38, A.2.3

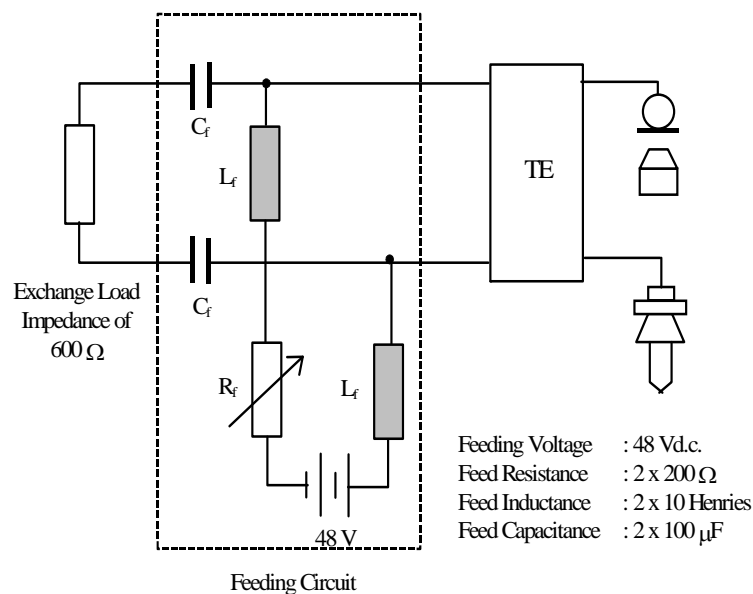

**Figure A.1: Circuit for measurement of transmission characteristics**  
(Refer to Figure A.1/ETSI TBR 38)

## Annex B: 2-Wire Analogue Leased Line Requirements

If TE is intended for use on 2-wire analogue leased lines, then the following additional requirements are applicable.

B.1	Longitudinal Conversion Loss (LCL)	CR	Remarks
	Longitudinal Conversion Loss (LCL) of the TE interface shall be $\geq 40$ dB in the frequency range of 300 to 600 Hz and $\geq 46$ dB in the frequency range of 600 to 3400 Hz.	M	Acceptable test method: ETSI TBR 21, A.4.7.4
B.2	Signal Frequencies and Sending Levels	CR	Remarks
B.2.1	All signals transmitted to public telecommunication network line shall be nominally confined to the frequency range of 300 to 3400 Hz and the power level during any 10 second period shall not exceed $-6$ dBm when measured with $600 \Omega$ termination.	M	Acceptable test method: ETSI TBR 21, A.4.7.3.1
B.2.2	Any power transmitted above 3400 Hz shall be reduced progressively by at least 12 dB/octave.	M	Acceptable test method: ETSI TBR 21, A.4.7.3.4
B.2.3	Any individual spectral component of the transmitted signals into the public telecommunication network line shall not exceed $-33$ dBm at frequencies above 3.4 kHz and $-70$ dBm at 50 kHz and above.	M	Acceptable test method: ETSI TBR 21, A.4.7.3.4
B.2.4	The transmission of d.c. and low frequency ac signals may be allowed on local leased circuits provided over physical lines. Where allowed, the maximum level of such signals and ripple components transmitted by the equipment to line shall not exceed the values indicated in Table B.1.	Note 1	
Note 1 Applicable only if TE is connected to the local leased circuits of SingTel's PSTN.			

**Table B.1: Maximum level of D.C. and low frequency signals for private leased local circuits allowed over physical lines**

Frequency Range (Hz)	Maximum Level	Remarks
D.C.	60 V 80 V	Maximum current to line must not exceed 50 mA d.c. For telegraph signalling only
5	30 V peak	Maximum current to line must not exceed 10 mA a.c.
6 - 100	7 V r.m.s. 30 V peak 85 V r.m.s.	Without a filter With 200 Hz LPF For 24 Hz (nominal) interrupted ringing only.
100 - 200	3.5 V r.m.s. 10 V r.m.s.	Without a filter With 200 Hz LPF
200 - 3400	$-6$ dBm	Terminated 10 seconds mean total power in $600 \Omega$ .

---

## Technical Information on Singtel Private Leased Voice Grade Circuits

### 1. Local Leased Circuits

Local leased voice grade circuits are provided between destinations in Singapore over a combination of subscriber lines (between subscribers and local exchanges) and junction lines (between exchanges).

### 2. Subscriber Lines

Existing subscriber lines use unloaded distribution cables with conductor gauges of 0.32 mm, 0.4 mm, 0.5 mm, 0.63 mm and 0.9 mm. The planning of the subscriber-line network takes into account the criterion that the line attenuation should be limited to a maximum of 7.7 dB at 1 kHz or a d.c. loop resistance of 1200  $\Omega$ , whichever is exceeded first.

### 3. Junction Lines

The present network of exchanges is interconnected by mainly 0.63 mm and 0.9 mm loaded junction cables and PCM links of the 2.048 Mbit/s types. For the loaded cable pairs, the attenuation has a low pass characteristic with a well-defined cut-off frequency at around 3.7 kHz. PCM circuits, on the other hand, conform to ITU-T Rec G712.

### 4. Characteristics of Local Leased Circuits

The characteristics of an ordinary local leased voice grade circuit are in accordance with ITU-T Rec M1040. The nominal overall loss of the circuit at the reference frequency between two arbitrary subscriber distribution points is not greater than 28 dB and the nominal psophometric noise power does not exceed -50 dBm. When used as the national section of an international leased voice grade circuit, the transmission loss of the local leased line is kept within 13 dB.

### 5. International Leased Voice Grade Circuits

These circuits are provided in accordance with ITU-T Rec M1040, M1025 or M1020 to match the type of circuits specified by the subscriber.

### 6. Data Transmission Over Local Leased Circuits

Singapore public telecommunication line distribution network is designed for voice transmission purpose. It is therefore not possible for the public telecommunication network to assure the quality of data transmission over the telephone lines. It is the supplier's responsibility to advise users of the line transmission characteristics that are required for the operation of their equipment and perform the necessary line conditioning.

The unconditioned voice grade leased circuit can generally support data transmission speeds up to 2400 bit/s at a bit error rate of  $1 \times 10^{-5}$ . For data transmission speeds of 4800 bit/s and above, line conditioning to ITU-T Rec. M1020 standard may be required.

## Annex C: Call Detail Recording Facilities

If call detail recording facility is incorporated in the equipment, then the following requirements are applicable.

C	Call Detail Recording Facilities	CR	Remarks
C.1	The start and stop of timing of the call duration are activated by permanent line reversal.	M	
C.2	The structuring and programming of tariff tables for STD and IDD calls shall take into account the international public telecommunication number structure as shown in Figure C.1.	M	
C.3	The structuring and programming of tariff tables for STD and IDD calls shall take into account the access codes (prefixes for discriminating between international network operators and/or the different network services they provide) and the tariff rates (the charge units) that are obtainable from network operators.  Note: Tariff rates are subject to change.	M	

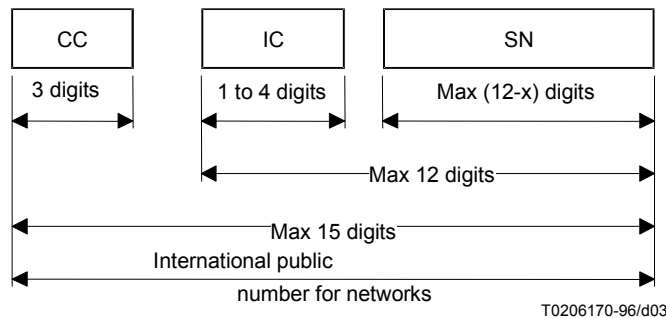

CC Country Code for  
 IC Identification Code  
 SN Subscriber Number  
 x Number of digits in Identification Code

NOTE – National and international prefixes are not part of the international public telecommunication number for Networks.

**Figure C.1: International Public Telecommunication Number Structure (Figure 3/E.164)**

## Annex D: Cordless Telephone Facility

If the TE is a cordless telephone or telecommunication system which transmits within any of the authorised frequency bands and power limits indicated in the relevant IDA technical specifications for radio-communication equipment, then the following requirements are applicable.

<b>D</b>	<b>Cordless Telephone Facility</b>	<b>CR</b>	<b>Remarks</b>
	The TE shall also comply with the relevant requirements given in:  (a) Technical Specification for Cordless Telephones and Cordless Telecommunication Systems (IDA TS CT-CTS); and/or  (b) Technical Specification for Short Range Devices (IDA TS SRD)	M	

## Annex E: Requirements for Coinafon

If the TE is a coinafon or incorporates coin collection facility, then the following requirements are applicable (coinafon or coin phone is a payphone designed to accept coins as the means of payment).

<b>E.1</b>	<b>Call Charging</b>	<b>CR</b>	<b>Remarks</b>
E.1.1	TE shall commence call charging upon detecting the reversal of line voltage polarity from the exchange when the called party answers the call and effect the collection of the first 10 ¢ coin.	M	
E.1.2	If the equipment is unable to detect the reversal of line polarity, it shall be provided with a prominent notice with clear user instructions on the method of operation and the deposit of coins.	M	
E.1.3	It shall be able to accept only Singapore 10 ¢ coins.	M	
E.1.4	It can be modified to accept the old Singapore 10 ¢ coins, if required.	M	
E.1.5	Call timing shall commence the moment the coin drops in by its own self-timing mechanism.	M	
E.1.6	The timer shall be set to the charging rate of 10 ¢ per X-minute block. X shall be equal to or greater than 2, and can be changed to greater than 2, if required.	M	
E.1.7	When the presence of a 10 ¢ coin is not detected after the called party answers, forced release shall be activated immediately by the coinafon.	M	
E.1.8	State whether the equipment can be modified to accept 20 ¢, 50 ¢ and \$1.00 Singapore coins.	M	

<b>E.2</b>	<b>Refund Facilities</b>	<b>CR</b>	<b>Remarks</b>
E.2.1	If the called party does not answer or if the line is busy, there shall be no coin collection.	M	
E.2.2	All unused coins shall be refunded when the handset is replaced.	M	
E.2.3	If unused coins other than the first 10 ¢ coin are not refundable, the equipment shall be provided with a prominent notice to warn the user and advise him to insert coins, one at a time.	M	

<b>E.3</b>	<b>Credit Expiry Warning</b>	<b>CR</b>	<b>Remarks</b>
E.3.1	A 400 Hz warning tone of 1 s on and 3 s off shall be sent from the TE 16 s before the call is terminated.	M	
E.3.2	The level of the warning tone, at the receiver, shall be between 55 dB(A) and 74 dB(A).	M	

<b>E.4</b>	<b>Emergency Free Call</b>	<b>CR</b>	<b>Remarks</b>
E.4.1	The equipment shall be able to recognise a coin free call when there is a detection of no reversal in line polarity.	M	
E.4.2	If the equipment is unable to detect line polarity reversal, it shall be programmable to allow coin free calls, for example, to Emergency numbers (999 and 995) and 1800 toll-free numbers.	M	

<b>E.5</b>	<b>Trunk Barring</b>	<b>CR</b>	<b>Remarks</b>
E.5.1	The equipment shall have a key mechanism such that when the key is not used: (a) local calls are payable; (b) called numbers beginning with digit '0' and called levels such as '100', '104', '105' and '1900' shall be trunk-barrred.	M	
E.5.2	When the key is used, coin-free calls can be made and the equipment is not trunk-barrred.	M	

<b>E.6</b>	<b>Incoming-Call Barring</b>	<b>CR</b>	<b>Remarks</b>
	For protection against fraudulent usage, the TE should have the option to bar incoming calls to prevent unauthorised collect calls.	M	Note 1

Note 1: The network operator offers a package of coinafon network facilities. It includes the facility for suppressing the calling-number identification as well as facilities for the barring of incoming calls, trunk calls and access to levels 100 (directory assistance), 104 (operator assisted international calls), 105 (call bookings) and 1900 (Premium Information Service).

<b>E.7</b>	<b>Reliability</b>	<b>CR</b>	<b>Remarks</b>
E.7.1	A test report on the reliability of the timing and coin collecting mechanism shall be submitted. (The reliability tests should be based on a sample size of at least 8 units.)	M	
E.7.2	The equipment housing should be of a sufficiently robust material such as the high resilience ABS plastic.	M	

## Annex F: Requirements for Credit Card, Phonocard, ATM Card, Cashcard and Multi-Coin Payphone

If TE is a Credit Card, Phonocard, ATM card, CashCard, Multi-Coin payphone or incorporates one or more of these means of payment collection facility, the following requirements are applicable.

F.1	General	CR	Remarks
F.1.1	If the equipment is capable of accepting Commercial Credit Cards <sup>2</sup> as the means of payment, it shall be able to communicate with the Credit Card Companies' host computers through dial-up access.	M	
F.1.2	If the equipment is capable of accepting ATM <sup>3</sup> cards and CashCards or chip/smart cards <sup>4</sup> issued by Banks and NETS <sup>5</sup> as the means of payment, it shall be able to communicate with the NETS' host computer through dial-up access.	M	
F.1.3	If the equipment is capable of accepting phonecards issued by the public network operator as the means of payment, it shall have facilities for storage and retrieval of the transaction records.	M	
F.1.4	If the equipment is a Multi-coin Payphone, (a) it shall be able to accept multiple Singapore coins of \$1.00, 50¢, 20¢ and 10¢ denominations as a means of payment; (b) the equipment shall be equipped with a single coin entry slot where coins shall be channelled to an intelligent coin-validator for validation check before acceptance; (c) the equipment shall return unacceptable coins to the refund tray immediately; (d) when a coin is accepted by the equipment, the credit shall be updated and displayed.	M	
F.1.5	The equipment shall have a display unit to: display the credit balance of the inserted phonocard and coins before dialling and during the conversation; display the digits of the number dialled; display the operating status, e.g. when the equipment is busy communicating with the NETS' host computer, or when it is in out-of-service condition; display guiding instructions on the call procedures.	M	
F.1.6	The equipment shall comply with all the relevant technical requirements in other parts of the IDA TS PSTN 1.	M	
F.1.7	The functioning of the equipment shall be independent of the exchange line polarity.	M	

<sup>2</sup> These are magnetic-encoded commercial credit cards that conform to the ISO Standards 7813 Track 2.

<sup>3</sup> ATM (Automatic Teller Machine) cards that conform to the ISO Standards 7813.

<sup>4</sup> These are cards that conform to the ISO Standards 7816 Part 1, 2 and 3.

<sup>5</sup> Networks for Electronic Transfers (Singapore) Pte Ltd.

<b>F.2</b>	<b>Call Charging</b>	<b>CR</b>	<b>Remarks</b>
F.2.1	The equipment shall have a self-tariffing facility and be able to compute the conversation time based on the credit balance and tariff rate of the called number.	M	
F.2.2	The equipment's self-tariffing tables shall be set to the prevailing STD and IDD rates and comply with clauses C.2 and C.3 of Annex C to the IDA TS PSTN.	M	
F.2.3	The equipment shall have the means for remote updating of tariff data.	M	
F.2.4	The equipment shall check the credit balance before sending the dialled digits to the public exchange. If the credit balance is less than the required minimum fee to make the call, the user shall not be allowed to continue with the call.	M	
F.2.5	The equipment shall commence charging only upon detection of permanent line polarity reversal.	M	
F.2.6	The equipment shall be able to force release the successful call when it detects that there is no more credit.	M	
F.2.7	When permanent line polarity reversal is not detected in the case of a successful local call, the equipment shall treat the call as to a free number.	M	
F.2.8	When permanent line polarity reversal is not detected in the case of a STD or IDD call, the transmitter of the equipment shall be muted and the equipment shall force release the call after a supervision period of 90s from the completion of the call set-up.	M	
F.2.9	For local calls, the equipment shall allow only "n" number of digits dialled before the detection of permanent line polarity reversal, where "n" is programmable.	M	
F.2.10	An initial fee (10¢ for STD calls, and 30¢ for IDD calls) shall be deducted from the credit when the call is answered. The debiting procedure shall be in accordance with Figure F.1.	M	
F.2.11	The equipment shall be able to charge calls to special service numbers such as "1900-XXXXXXX" (Premium Information Service) at tariff rates different from local calls e.g. at a flat rate of X cents per call.	M	

<b>F.3</b>	<b>Refund Facilities</b>	<b>CR</b>	<b>Remarks</b>
F.3.1	If the called party does not answer or if the line is engaged, there shall be no debiting or collection of coins.	M	
F.3.2	All unused coins shall be returned to the refund tray by the equipment when the user replaces the handset.	M	

<b>F.4</b>	<b>Warning Facilities</b>	<b>CR</b>	<b>Remarks</b>
F.4.1	The equipment should have a warning facility to remind user to collect the returned card after the handset is replaced at the end of the call.	M	
F.4.2	The equipment shall have warning signals to inform the user that the credit balance is running low at an instant before the equipment terminates the call.	M	
F.4.3	In the case of multi-coin payphone, if the user inserts more valid coins before the credit expires, the call shall be allowed to continue.	M	
F.4.4	The warning signals shall comprise both tone on the receiver of the handset and a flashing message at the display. The warning tone shall be as follows: (a) for local calls, a 400 Hz tone of 1 second on and 3 seconds off shall be generated by the equipment; (b) for STD and IDD calls, only a one-pip 400 Hz tone shall be generated by the equipment; (c) level of the tone at the receiver shall be between 55 dB(A) and 74 dB(A).	M	

<b>F.5</b>	<b>Free Calls</b>	<b>CR</b>	<b>Remarks</b>
F.5.1	The equipment shall allow the programming of free numbers such as emergency numbers (999 and 995), and calls to these numbers shall not require the slotting in of card or the insertion of coins.	M	

<b>F.6</b>	<b>Protection against fraudulent usage</b>	<b>CR</b>	<b>Remarks</b>
F.6.1	The equipment should have security features e.g. preventing the tampering of tariff rates, functions for authentication of cards and intelligent coin-validator.	M	
F.6.2	For protection against fraudulent usage, the equipment shall have an option to bar incoming calls to prevent unauthorised collect calls, and access to levels 104, 105 and 1635 (for operator assisted international calls and call bookings).	M	

<b>F.7</b>	<b>Reliability</b>	<b>CR</b>	<b>Remarks</b>
F.7.1	The equipment should be capable of self-diagnosis and identification of any fault e.g. common faults related to the Credit Card.	M	
F.7.2	There shall be accuracy in the charging. The difference in timing between the given conversation time and the computed conversation time shall not be more or less than 0.05%.	M	
F.7.3	A test report on the reliability and accuracy of the timing and coin collecting mechanism (where applicable) shall be submitted (the tests conducted should be based on a sample size of at least 8 units).	M	
F.7.4	The equipment housing should be of a sufficiently robust material such as the high resilience ABS plastic.	M	

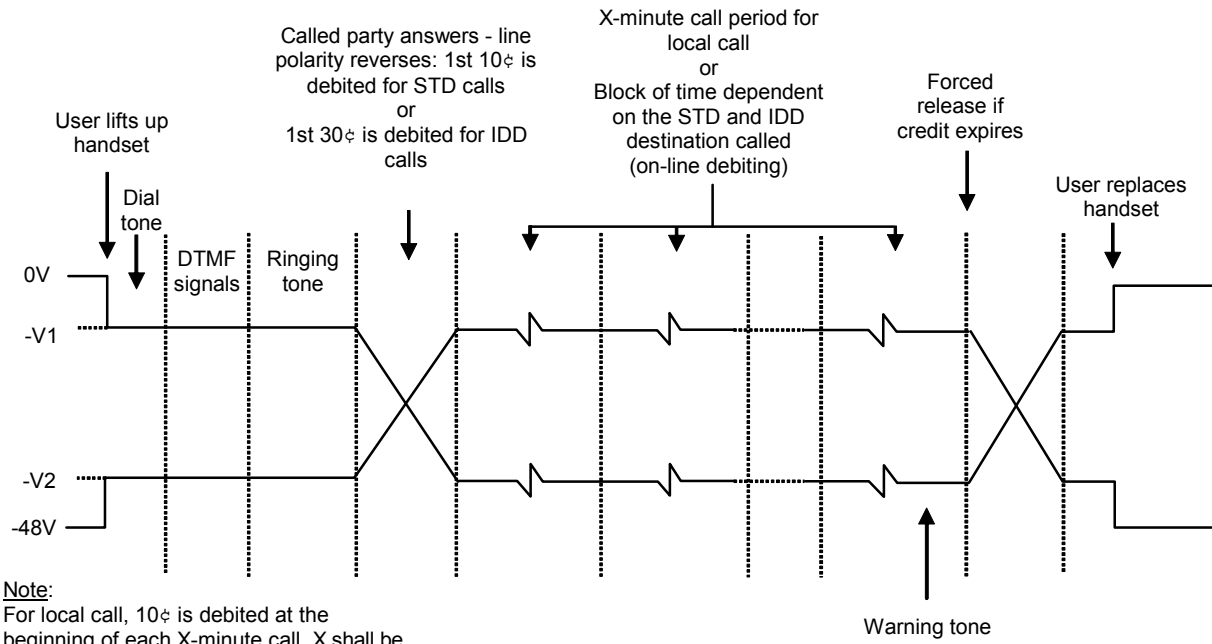

Figure F.1: Debiting Procedure

## Annex G: Requirements for Caller Identity Equipment

If the equipment incorporates Analogue Calling Line Identity Presentation (Caller ID) facility in accordance with IDA TS ACLIP, then the following requirements are applicable. The caller identity equipment shall be of Type 1, which supports on-hook data transmission with power ringing. Power ringing includes ringing of any distinctive pattern or a first burst.

G.1	General	CR	Remarks
G.1.1	The equipment shall be able to receive A-CLIP information while it is in on-hook condition (unlooped condition) and during the silent interval between the first and second ringing signal received (refer to Figure A-1 of IDA TS ACLIP: 2005).	M	
G.1.2	The equipment must conform with the ITU-T Rec T.50 for the display of Calling Line Identification (CLI) and name of the calling party.	M	
G.1.3	The equipment shall comply with all the relevant technical requirements in other parts of this Specification.	M	

G.2	PSTN-to-Terminal Equipment Information Signalling	CR	Remarks
G.2.1	<p>Data signalling interface for A-CLIP facility shall conform with the following parameters:</p> <ul style="list-style-type: none"> <li>(a) The equipment shall be connected to the PSTN by a two-wire simplex link.</li> <li>(b) The equipment shall be able to receive from an analogue, phase coherent frequency shift keying (FSK) transmission scheme.</li> <li>(c) The logical 1 (mark) is <math>1200 \pm 12</math> Hz.</li> <li>(d) The logical 0 (space) is <math>2200 \pm 22</math> Hz.</li> <li>(e) The transmission rate is 1200 bit/s.</li> <li>(f) The application of data is in serial, binary and asynchronous.</li> <li>(g) The bit error rate (BER) is <math>\leq 1</math> out of 100,000 bits.</li> <li>(h) Phase continuity is maintained from beginning of service to the end of the message.</li> <li>(i) The equipment's receiver sensitivity shall be <math>-26</math> dBm <math>\pm 2</math> dBm.</li> <li>(j) The bit duration is <math>833 \pm 50</math> <math>\mu</math>s (start and stop bits have the same duration as a standard bit).</li> </ul>	M	

G.3	PSTN-to-Terminal Equipment Information Signalling	CR	Remarks
G.3.1	The equipment shall be able to receive data messages according to the following protocols:	–	
G.3.1.1	The information is transmitted in a series of 8-bit data words each bounded by a start bit (space) and a stop bit (mark), and is segmented according to the Single Data Message Format (SDMF) or the Multiple Data Message Format (MDMF) as shown as in Figures 1 and 2 of IDA TS ACLIP: 2005.	M	
G.3.1.2	The data shall be received in the order of the least significant bit first.	M	
G.3.1.3	Data messages not recognised by the equipment shall be ignored.	M	
G.3.1.4	If the equipment recognises the message type word of the multiple data message but does not recognise one or more of the parameter type words within the multiple data message, the equipment shall process all the recognised parameter type words and ignore all the unrecognised parameter type words.	M	
G.3.1.5	On receiving each data message (single or multiple) the equipment shall be able to switch "on", provide the data to be displayed and then switched "off".	M	
G.3.2	Contents of data message	–	Heading
G.3.2.1	The equipment shall be able to support the 2 message type words and the 4 parameter type words as defined in clause 2.3, tables 2, 3 and 4 of IDA TS ACLIP: 2005.	M	
G.3.2.2	The equipment shall respond correctly to a Channel Seizure Signal consisting of a block of 300 continuous bits of alternating "0"s and "1"s (first bit to be "0") and a following Mark (logic 1) Signal consisting of 180 mark bits used to alert and condition the equipment for the reception of a message frame.	M	
G.3.2.3	The equipment shall be able to support the data message formats used by Singapore PSTN to convey A-CLIP service information as shown in Annex B of IDA TS ACLIP: 2005.	M	
G.3.3	Error Detection	–	Heading
	The last word of the Single or Multiple Data Message is the checksum word and it shall be used for error detection. At the equipment the checksum shall be recomputed by the two's complement of the modulo 256 sum of each bit in all the other words in the message, and then compared with the checksum word received in the message. If both values are identical, the received message shall be considered as error free.	M	

---

<b>G.4</b>	<b>Terminal Equipment-To-PSTN Information Signalling</b>	<b>CR</b>	<b>Remarks</b>
	The equipment shall not initiate any data transmission to the PSTN.	M	

<b>G.5</b>	<b>If Caller ID facility is incorporated in a KTS, PABX or other call switching system, then the following requirements must be met:</b>	<b>CR</b>	<b>Remarks</b>
G.5.1	The Caller ID receiver shall be directly connected to the PSTN at the exchange line interface of the call switching system.	M	
G.5.2	The call switching system shall be able to transfer the Caller ID and/or other relevant information for display at the extension telephone for every call transfer.	M	
G.5.3	The applicant shall submit a statement or test report confirming that the Caller ID facility has been field-tested to work correctly with the PSTN.	M	

## Annex H: Requirements for Call Switching Equipment

If TE is a Call Switching Equipment, then the following requirements are applicable.

H	Requirements for Call Switching Equipment	CR	Remarks
H.1	For an installation of call switching equipment, the connection point to the public telecommunication network shall be located at an IDF provided by the customer. The IDF shall also provide test and isolation access to each exchange circuit to the equipment (see Figure H.1).	M	
H.2	Where the coding of voice-frequency signals for digital switching is by means of PCM, A-law companding as defined in ITU-T Rec G.711 should be adopted.	O	

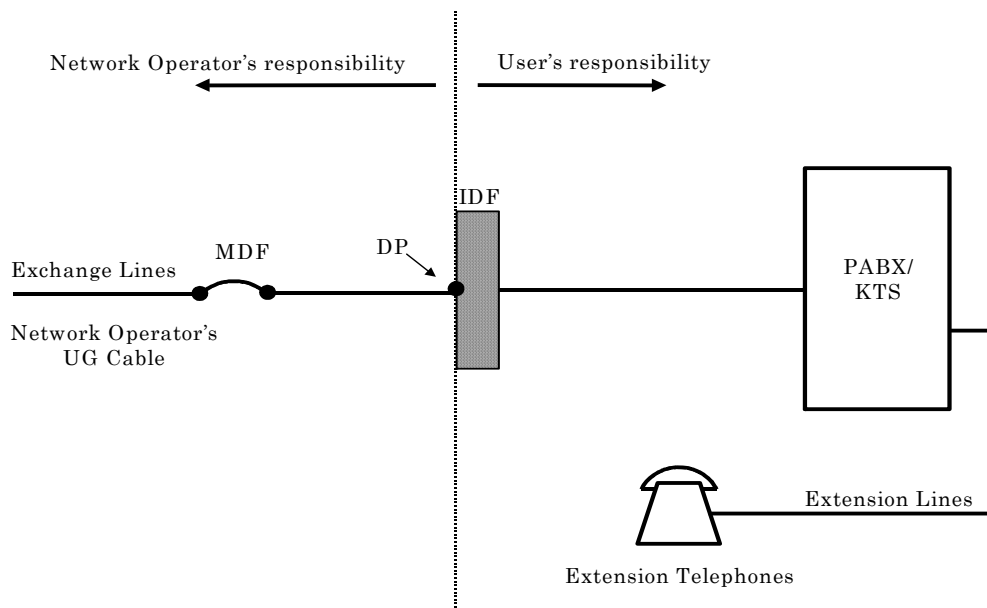

Figure H.1: Method of connection for Call Switching Equipment

## Annex I: Requirements for Direct Inward Dialling Facility

If Direct Inward Dialling facility employing a variant of ITU-T R2 signalling system as adopted in Singapore PSTN is provided, then the following requirements are applicable.

I.1	Line Signalling	CR	Remarks
I.1.1	DID circuit is powered by $-48\text{ V} \pm 5\text{ V}$ d.c. supply from the PABX.	M	
I.1.2	The maximum current drain during the idle line state shall not exceed 5 mA.	M	
I.1.3	The minimum feed current during the line seizure state shall be at least 16 mA.	M	
I.1.4	The d.c. line signalling between PABX and terminating exchange shall be in accordance with Table I.1.	M	

I.2	Register Signalling	CR	Remarks
I.2.1	The MFC register shall be equipped to interwork with 2-out-of-6 forward signals and 2-out-of-5 backward signals (2-out-of-4 backward signals is acceptable conditionally, see clause I.3.5). The frequency combinations for the signal codes are as specified in Table I.2.	M	
I.2.2	The forward and backward signal codes shall be used for indicating / controlling functions as specified in Table I.3.	M	
I.2.3	The MFC signalling sequence for DID calls shall be according to Figure I.1.	M	
I.2.4	The sending part of MFC signalling equipment shall conform to ITU-T Rec. Q.454.	M	
I.2.5	The receiving part of MFC signalling equipment shall conform to ITU-T Rec. Q.455.	M	
I.2.6	The equipment shall be capable of receiving signalling information from the exchange at a nominal rate of six digits per second.	M	
I.2.7	The supervision of the PABX incoming register should be provided to ensure that the clear-back is sent when: (a) Interval between the seizure of the register and the receipt of the first forward MFC signal is $> 5\text{ s}$ . (b) Interval between two successive forward MFC signals is $> 5\text{ s}$ .	M	
I.2.8	The PABX incoming register shall be disconnected within 30 ms after recognition of the end of transmission of the last backward signal.	M	
I.2.9	The speech path at the PABX shall not be through connected until 75 ms after the end of transmission of the last backward signal.	M	

I.3	Switching of DID calls	CR	Remarks
I.3.1	All DID circuits shall be 2-wire and unidirectional.	M	
I.3.2	MFC signalling equipment shall be connected to circuit within 500 ms after circuit seizure.	M	
I.3.3	If the called extension is free, the PABX shall return MFC B1 signal for the through connection to occur, and apply ringing current to the called extension and ringing tone to the calling party until the extension answers the call or a clear forward signal is received. The ringing tone shall be 425 Hz and having a periodicity of 0.4 s on, 0.2 s off, 0.4 s on and 2 s off.	M	
I.3.4	If the called extension is engaged, the PABX shall return MFC B2 signal and await clear forward signal before restoring the DID circuit to idle state. The originating exchange on receipt of MFC B2 signal, will send busy tone to the calling party.	M	
I.3.5	If the DID numbers received at the PABX are recognised as denied or unalloted numbers, the PABX shall take one of the following actions: (a) Return MFC B1 signal at call set-up and divert the call to operator for attention; or (b) Return MFC B1 signal at call set-up. Cause NU tone to be sent to the calling party. The PABX shall not give an answer signal; or (c) Return MFC B7 signal and await clear forward signal before restoring the DID circuit to idle state. The originating exchange will send Number Unobtainable (NU) tone to the calling party.	M	
I.3.6	For a DID call from trunk offering operator, test operator (i.e. line test desk), interception operator or trunk / gateway exchange (based on forward II signals 1, 7, 8 or 9 received respectively), the PABX should divert the call to the PABX operator for attention and return MFC B1 signal.	M	

Table I.1: DID Line Signalling

Line State	Interface Condition at		Remarks
	Terminating Exchange	PABX	
Idle	H	N	DID circuit ready for new call
Seizure	H → L	N	Signal from Terminating Exchange
Answer/Reanswer	L	N → R	Extension or operator has answered or reanswered call
Clearback	L	R → N	Called party has cleared
Clear Forward	L → H	N ) R ) → N	On receiving this signal, PABX clears connection and restores circuit to idle state
Back-busy	H	S/R	Circuit is blocked at the PABX end for maintenance purpose and not available for seizure

## Legend:

H = High ohmic loop (greater than 20,000 ohms)

L = Low ohmic loop (400 to 900) ohms

N = Battery feed with a lead -ve and b lead +ve (0V)

R = Battery feed with a lead +ve and b lead -ve (-48V)

S = Battery removed from leads

Table I.2: Frequency Combination for MFC Signal Codes

Signal	Forward Signals for Gp I and Gp II (Hz)	1380	1500	1620	1740	1860	1980
	Backward Signals for Gp A and Gp B (Hz)	1140	1020	900	780	660	–
	Weight	0	1	2	4	7	11
1		X	X				
2		X		X			
3			X	X			
4		X			X		
5			X		X		
6				X	X		
7		X				X	
8			X			X	
9				X		X	
10					X	X	
11		X					X
12			X				X
13				X			X
14					X		X
15						X	X

Table I.3: Allocation of MFC Codes for DID

Signal	Forward Signals		Backward Signals	
	Group I	Group II	A-Signals	B-Signals
1	Digit 1	Operator with trunk offering	Send next digit of called number	Called party free
2	Digit 2	Ordinary subscriber or operator without trunk offering	*	Called party busy
3	Digit 3	Payphone	Send category of calling subscriber and prepare to receive B-signal	*
4	Digit 4	Subscriber with CLI non-display service	Congestion	Congestion
5	Digit 5	Coinafon	*	*
6	Digit 6	Test equipment	*	*
7	Digit 7	Line test desk	*	Unallocated/denied number
8	Digit 8	Interception operator	*	*
9	Digit 9	Call from transit exchange	*	*
10	Digit 0	Transferred call	*	*
11-15	#	Reserved for future use	#	#

Notes : 1. The DID PABX shall not send any of the signals marked \*

2. Signals marked # would not be used for DID PABX

3. The DID PABX shall be able to receive and treat the call accordingly to the type of Group II signal (i.e. any one of the Group II/1 to Group II/15) received. Where a Group II signal is not defined (i.e. reserved), the DID PABX shall treat the call in the same way as for a Group II/2 signal received

4. For B7 signal, see also clause I.3.5

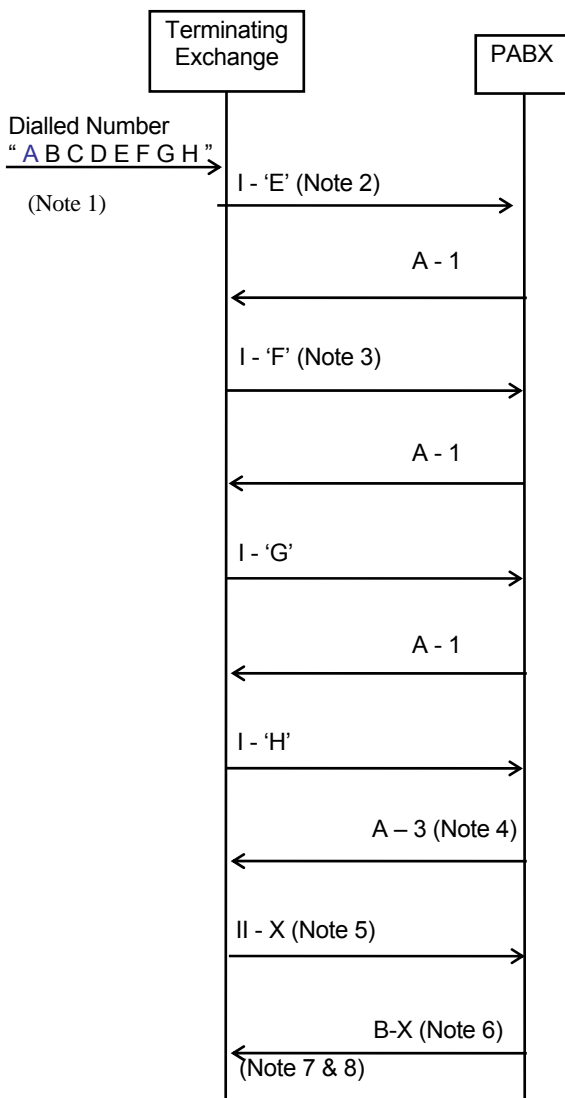

Note:

- (1) The terminating exchange on receiving sufficient number of digits to determine the DID route will seize an idle DID circuit.
- (2) Starting point of signalling to send last 4 digits to PABX.
- (3) Starting point of signalling to send last 3 digits to PABX
- (4) If A-4 is returned, the outgoing exchange will return congestion or busy tone to the calling subscriber and then perform line lock out.
- (5) Can be any one of the Group II-1 to II-15 signals.
- (6) Only one of the following B signals shall be returned: B1, B2, B4 or B7. On receipt of B-4, the outgoing exchange shall send busy tone to the calling subscriber.
- (7) The B-X signal shall be returned within 2 seconds following the reception of the II-X signal.
- (8) The overall MFC signalling shall, under normal conditions, take not more than 3 seconds.

Figure I.1: MFC Signalling Sequence for DID Call

## Annex J: Input Procedure for Sending Alphanumeric Characters

**Coding Table for Alphanumeric Paging Input through Telephone Keypad**

Alphanumeric Character	First Keystroke	Second Keystroke
Alpha shift	#	#
A	2	1
B	2	2
C	2	3
D	3	1
E	3	2
F	3	3
G	4	1
H	4	2
I	4	3
J	5	1
K	5	2
L	5	3
M	6	1
N	6	2
O	6	3
P	7	1
Q	7	2
R	7	3
S	7	4
T	8	1
U	8	2
V	8	3
W	9	1
X	9	2
Y	9	3
Z	9	4
Numeric Shift	*	#
1	1	
2	2	
3	3	
4	4	
5	5	
6	6	
7	7	
8	8	
9	9	
0	0	
End	*	*
Space	*	1
-	*	2
.	*	3
\$	*	4
&	*	5
%	*	6
?	*	7
Backspace	*	8
Reserved for value-added services	#	0 to 9

**Paging Procedure**

**A Using a push-button telephone keypad and coding table, for alphanumeric paging :**

1. Dial the called party's pager number.
2. Wait for the beeping tone or voice response from the system (note 1).
3. Press # key once to switch to Alphanumeric Paging Input (API) mode (note 2).
4. Listen for the fast beep tone (indicating system is in API mode).
5. Enter the message according to the API coding table.
6. Enter \*\* to end the message.
7. Wait for the normal beep tone (indicating the page has been accepted).
8. Replace the telephone handset.

**B Using a message entry device:**

The same API coding table and above procedure are also applicable for the automatic transmission of text messages for alphanumeric paging.

**Note:**

- 1 The voice response can be interrupted by the caller pressing any key on the keypad.
- 2 Instead of pressing the # key, caller can press the \* key to switch system to numeric paging mode.
- 3 Normal beep tone is 2000 Hz tone transmitted at -10 dBm at periodicity of 125 ms on and 125 ms off.
- 4 Fast beep tone is 2000 Hz tone transmitted at -10 dBm at periodicity of 100 ms on and 50 ms off.

## Annex K: Requirements for Short Message Service (SMS)

If the equipment supports the exchange of Short Messages over the PSTN and is a Short Message Terminal Equipment (SM-TE), then the following requirements are applicable.

K.1	SMS for PSTN Service Description	CR	Remarks
K.1.1	The equipment shall incorporate the core service features as described in ETSI ES 201 986 V1.1.2 (2002-01).	M	Note 1
K.1.2	The equipment shall comply with the Short Message transfer principle as described in section 4 of ETSI ES 201 912 V1.1.1 (2002-01).	M	
K.1.3	The equipment shall have the capability to evaluate the caller ID information according to ETSI EN 300-659-1 for Frequency Shift Keying (FSK) signalling.	M	
Note 1: User Based Solution is implemented by SingTel's network.			

K.2	Short Message (SM) Communication between a fixed network SM-TE and a SM-SC (Short Message Service Centre)	CR	Remarks
K.2.1	The SM-TE shall comply with Protocol 1 (fully compliant with the GSM SMS) as described in section 5 of ETSI ES 201 912 V1.1.1 (2002-01).	M	
K.2.2	The SM-TE shall support the SMS protocol for PSTN as defined by Protocol 1: <ul style="list-style-type: none"> <li>a) The Physical Layer shall comply with section 5.3.1 of the ES 201 912 and ETSI EN 300 659-2 for the FSK transmission function and ETSI EN 300 778-2 for the FSK receiving function.</li> <li>b) The Data Link Layer (DLL) shall comply with section 5.3.2 of the ES 201 912.</li> </ul>	M	
K.2.3	The SM-TE shall be capable of setting the minimum delay time (T <sub>10</sub> ) between the accepting of the call and the sending of the first FSK frame according to the integer value <i>n</i> to be defined by the network operator:  $T_{10min} = n \times 100 \text{ ms, where } n \text{ can be any value between 1 to 256}$	M	
K.2.4	The SM-TE shall be capable of supporting the SMS features as described in section 5.5 of the ES 201 912.	M	
K.2.5	The SM-TE shall be capable of handling all incoming calls bearing SM according to section 5.5.6 and Table 3 of ES 201 912.	M	
K.2.6	The SM-TE shall be capable of handling outgoing calls according to section 5.5.7 of ES 201 912.	M	

## Annex L: Requirements for POTS Splitter/Line Filters for use with ADSL Services

If the equipment incorporates POTS splitter or line filters for ADSL application, then the following requirements are applicable. Requirements have been adapted to Singapore's PSTN requirements with cross-references taken from Annex E.1/G.992.

L.1	Impedance Matching	CR	Remarks
	The reference impedance for voice terminal operation is 600 $\Omega$ .	M	Clause E.1.1/G.992
L.2	Return loss	CR	Remarks
	The return loss against 600 $\Omega$ in the frequency range of 300 Hz to 3400 Hz shall be >14 dB.	M	Clause E.1.2/G.992
L.3	Insertion loss	CR	Remarks
L.3.1	The TELE port to LINE port insertion loss shall be < 1 dB at 1 kHz for 600 $\Omega$ impedance.	M	Clause E.1.3/G.992
L.3.2	The insertion loss distortion in the frequency range of 300 Hz to 3400 Hz shall be < $\pm 1$ dB for 600 $\Omega$ impedance.	M	Clause E.1.4/G.992
L.4	Isolation	CR	Remarks
	(a) The insulation resistance between branch and the earth terminal shall be > 5 M $\Omega$ ; term = $\alpha$ $\Omega$ measured at 100 V d.c.  (b) The insulation resistance between branch and the branch terminal shall be > 1 M $\Omega$ ; term = $\alpha$ $\Omega$ measured at 100 V d.c.  (c) The DC resistance shall be < 80 $\Omega$ ; term = 0 $\Omega$ .	M	Clause E.1.5/G.992
L.5	Signal power	CR	Remarks
	The maximum power level in 300 Hz to 3400 Hz is < -6 dBm when measured with 600 $\Omega$ termination.	M	Clause E.1.6/G.992
L.6	Ringing	CR	Remarks
	TE shall be able to withstand ringing voltage of 75Vrms at ringing frequency of 24 Hz.	M	Clause E.1.7/G.992
L.7	Unbalance about earth	CR	Remarks
	Impedance unbalance about earth expressed in Longitudinal Conversion Loss (LCL) shall be $\geq 40$ dB in the frequency range of 300 to 600 Hz and $\geq 46$ dB in the frequency range of 600 to 3400 Hz, terminated with 600 $\Omega$ impedance.	M	Clause E.1.8/G.992

## Annex M: References

For the technical requirements captured in this Specification, reference has been made to the following documents:

ETSI TBR 21 (January 1998):	Terminal Equipment (TE); Attachment Requirements for pan-European approval for connection to the analogue Public Switched Telephone Networks (PSTNs) of TE (excluding TE supporting the voice telephony service) in which network addressing, if provided, is by means of Dual Tone Multi Frequency (DTMF) signalling
ETSI TBR 38 (May 1998):	Public Switched Telephone Network (PSTN); Attachment Requirements for a terminal equipment incorporating an analogue handset function capable of supporting the justified case service when connected to the analogue interface of the PSTN in Europe
ETSI TBR 15 (January 1997):	Business Telecommunications (BTC); Ordinary and Special quality voice bandwidth 2-wire analogue leased lines (A20 and A2S); Attachment Requirements for terminal equipment interface
EG 201 120 V1.1.1 (1998-01):	Public Switched Telephone Network (PSTN); Method of rating the terminal equipment so that it can be connected in series and/or in parallel to a Network Terminal Point (NTP)
ETS 300 001 (January 1997):	Attachments to Public Switched Telephone Network (PSTN); General technical requirements for equipment connected to an analogue subscriber interface to PSTN
FCC Part 68 (10-1-98 Edition):	Connection of terminal equipment to the telephone network
IEC 60950-1: 2001	Information Technology Equipment – Safety
IEC CISPR 22: 2003-04	Information Technology Equipment – Radio disturbance characteristics – Limits and methods of measurement
ITU-T Rec. E.161 (02/2001)	Arrangement of digits, letters and symbols on telephones and other devices that can be used for gaining access to a telephone network
ETSI EN 300 659-1 V1.3.1 (2001-01)	Subscriber line protocol over the local loop for display (and related) services; Part 1: On-hook data transmission
ETSI EN 300 659-2 V1.3.1 (2001-01)	Subscriber line protocol over the local loop for display (and related) services; Part 2: Off-hook data transmission
ETSI EN 300 778-1 V1.2.1 (2001-05)	Protocol over the local loop for display and related services; Terminal equipment requirements; Part 1: On-hook data transmission
ETSI EN 300 778-2 V1.2.1 (2001-05)	Protocol over the local loop for display and related services; Terminal equipment requirements; Part 2: Off-hook data transmission
ETSI ES 201 986 V1.1.2 (2002-01)	Short Message Service (SMS) for PSTN/ISDN; Service description
ETSI ES 201 912 V1.1.1 (2002-01)	Short Message Service (SMS) for PSTN/ISDN; Short Message Communication between a fixed network Short Message Terminal Equipment and a Short Message Service Centre

Note:

European Telecommunications Standards Institute (ETSI) Technical Basis for Regulation (TBR)  
Federal Communications Commission (FCC)  
ETSI Guide (EG)

## Annex N: Addendum/Corrigendum

<b>Changes to IDA TS PSTN Issue 1 Rev 1, Mar 07</b>			
Page	TS Ref.	Items Changed	Effective Date
		Change of IDA's address at cover page to Mapletree Business City.	1 May 11

<b>Changes to IDA TS PSTN Issue 1</b>			
Page	TS Ref.	Items Changed	Effective Date
15	Annex D	Requirements for Cordless Telephone facility has been amended to include the provisions given in IDA TS SRD.	1 Mar 07
		Following the announcement on 'IDA Relaxes Its Policy on Uniform Local Payphone Rate' on 31 Jan 07, the following annexes have been amended:	1 Mar 07
16	Annex E, E.1.6 and E.1.7	The two clauses have been combined and revised. The timer charging rate has been changed from "10 ¢ per 3-minute block" to "10 ¢ per X-minute block. X shall be equal to or greater than 2, and can be changed to greater than 2, if required".	
21	Annex F, Figure F.1	The Figure F.1 on Debiting Procedure has been updated to reflect the change in the timer setting for local call.	

<b>Changes to IDA TS PSTN 1 Issue 4 Rev 2</b>			
Page	TS Ref.	Items Changed	Effective Date
—	—	<p>Title of Specification has been renamed as "Technical Specification for Terminal Equipment connecting to the Public Switched Telephone Network (PSTN)" (IDA TS PSTN Issue 1).</p> <p>The IDA Type Approval Specification for Terminal Equipment for connection to Public Switched Telephone Network (IDA TS PSTN 1 Issue 4 Rev2) has been superseded by this Technical Specification</p> <p>This Technical Specification has also incorporated the EMC requirements, previously published under the IDA TS EMC Issue 1 Rev 1.</p> <p>Changes are mainly editorial in nature, in which the essential technical requirements for compliance remain unchanged.</p>	21 Jul 05