



Telecommunications  
Standards Advisory  
Committee (TSAC)

---

Next Generation  
National Broadband  
Network (NGNBN)

---

Optical Fibre  
Deployment

---

**IDA RS OFD  
Issue 1, XXX 2010**

Infocomm Development Authority of Singapore  
Resource Management & Standards  
8 Temasek Boulevard  
#14-00 Suntec Tower Three  
Singapore 038988

© Copyright of IDA, 2010

This document may be downloaded from the IDA website at <http://www.ida.gov.sg> and shall not be distributed without written permission from IDA.

## Acknowledgement

The Infocomm Development Authority of Singapore (IDA) and the Telecommunications Standards Advisory Committee (TSAC) would like to acknowledge the following members of the Technical Committee Working Group 1 (TSTC WG1) for their invaluable contributions to the preparation of this Reference Specification:

TSTC WG1 Chairman: Dr Yeo Yong Kee, A\*STAR/I<sup>2</sup>R

| S/N | Organisation  | Name  |
|-----|---|---|
| 1   | A*STAR/Institute for Infocomm Research (I <sup>2</sup> R) | Dr Chen Jian, Research Scientist  |
| 2   |   | Mr Liaw Chin Yi, Senior Research Officer                                      |
| 3   |   | Dr Wang Yixin, Senior Research Scientist                                      |
| 4   |   | Dr Cheng Xiaofei, Senior Research Fellow                                      |
| 5   |   | Dr Park Chul Soo, Research Fellow   |
| 6   |   | Dr Rong Weifeng, Research Fellow  |
| 7   |   | Dr Shao Xu, Senior Research Fellow  |
| 8   | BICSI Southeast Asia                                      | Mr Christopher Thiam Boon Kwee, Director<br>RFX Solutions Pte Ltd             |
| 9   | M1 Limited  | Mr Tan Pek Tong, Senior Manager   |
| 10  | Media Development Authority                               | Mr Lim Chin Siang, Director (IT & Technologies)                               |
| 11  | National University of Singapore                          | A/Prof. Yu Changyuan, Assistant Professor                                     |
| 12  | Nucleus Connect Pte Ltd                                   | Ms Khor Lay Khim, Senior Manager  |
| 13  | OpenNet Pte Ltd   | Mr Tiong Oon Seng, Project Director   |
| 14  | Singapore Telecommunications Ltd                          | Mr Wong Ching Ping, Deputy Director<br>(International Private IP Engineering) |
| 15  |   | Mr Tan Yoke Yin, Deputy Director (Access<br>System Engineering)               |
| 16  | StarHub Ltd   | Mr Tan Yong Teck, Principal Engineer  |

TSAC is responsible for the strategic direction, work programmes and procedures for standards-setting, and acts as the advisory body to IDA in meeting the needs of all stakeholders.

TSAC is supported by a Technical Committee (TSTC) where professional, trade and consumers' interest in information and communications is represented by a wide sector of the information and communications industry, comprising network operators, equipment suppliers and manufacturers, academia and researchers, professional bodies and other government agencies.

## TSAC Membership

### **TSAC Chairman:**

Mr Raymond Lee                      Director (Resource Management & Standards), Infocomm Development Authority of Singapore

### **TSAC Members:**

Mr Lim Yuk Min  
(TSAC Vice-Chairman)              Deputy Director (Resource Management and Standards), Infocomm Development Authority of Singapore

Assoc Prof Tham Chen Khong              Department Head, Agency for Science, Technology and Research

Mr Darwin Ho Kang Ming              Vice President, Association of Telecommunications Industry of Singapore

Mr Sandeep Bhargava              Association of Telecommunications Industry of Singapore, c/o Nokia Siemens Networks India Pte Ltd Head-Corporate Affairs (APAC Region)

Mr Lim Chin Siang                      Director (IT & Technologies), Media Development Authority

Mr Patrick Scodeller                      Chief Technical Officer, MobileOne Ltd

Assoc Prof Li Kwok Hung              Nanyang Technological University, School of Electrical & Electronic Engineering

Prof Ko Chi Chung                      National University of Singapore, Department of Electrical & Computer Engineering

Mr Simon Smith                         Senior Manager Regulatory, Pacnet Internet (S) Ltd

Mr Edwin Lok                             Manager (Engineering), Pacnet Internet (S) Ltd

Mr Lee Siak Kwee                        Director (Mobile Network Access), Singapore Telecommunications Ltd

Mr Tan Seow Nguan                      Director (Network System Engineering), Singapore Telecommunications Ltd

Mr Lim Cheow Hai                        Director (Access Engineering), Singapore Telecommunications Ltd

Mr Soh Keng Hock                        Director (Private IP Engineering & VAS), Singapore Telecommunications Ltd

Mr Lee Toon Huat                         Manager (Standardisation Division), Spring Singapore

Mr Peter Cook                             Vice President (Network Mobile Technology & Planning Group), StarHub Ltd

Mr Mah Chin Paw                         The Institution of Engineers, Singapore, AGM (Guthrie Engineering (S) Pte Ltd

Mr Liang Seng Quee                      Deputy Director (Network Infrastructure), Infocomm Development Authority of Singapore

Ms Woo Yim Leng                        Senior Manager (Resource Management & Standards), Infocomm Development Authority of Singapore

**TSAC Secretariat:**

Ms Tay Siew Koon

Manager (Resource Management & Standards), Infocomm Development  
Authority of Singapore

# Contents

| Section | Title                                       | Page |
|---------|---|------|
| 1.      | Scope                                       | 2    |
| 2.      | Abbreviations                               | 3    |
| 3.      | Safety Precautions                          | 4    |
| 4.      | Pre-testing Preparation                     | 5    |
| 5.      | Fibre Test Equipment and Techniques         | 6    |
| 6.      | Outside Plant and Optical Fibre Maintenance | 11   |
| 7.      | Device Conformance Certification            | 12   |
| 8.      | Network Performance Testing                 | 13   |
| 9.      | In-service Testing and Monitoring           | 14   |
| 10.     | References                                  | 16   |

*This Reference Specification is a living document which is subject to review and revision.*

*Reference Specifications and Guides are informative documents and are not used for approval of customer equipment. They are either one of the following types of documents:*

*Informative and interim documents on customer equipment standards which are yet to be adopted by network operators; or*

*Informative documents describing network standards adopted by the public telecommunication networks in Singapore.*

## **NOTICE**

**THE INFOCOMM DEVELOPMENT AUTHORITY OF SINGAPORE MAKES NO WARRANTY OF ANY KIND WITH REGARD TO THIS MATERIAL AND SHALL NOT BE LIABLE FOR ERRORS CONTAINED HEREIN OR FOR INCIDENTAL OR CONSEQUENTIAL DAMAGES IN CONNECTION WITH THE USE OF THIS MATERIAL.**

## **Testing and Monitoring of Passive Optical Access Networks**

### **1 Scope**

After the fibres of a Passive Optical Network (PON) system are deployed, various performance tests should be performed to ensure that the network meets the functional requirements. The tests can be classified as pre-operation tests and in-service tests, and both are covered in this chapter. In addition, commonly used test equipment and optical measurement techniques are also introduced.

## 2 Abbreviations

This Reference Specification uses the following abbreviations:

|      |  |
|------|--|
| PON  | Passive Optical Network                    |
| IEC  | International Electrotechnical Commission  |
| ANSI | American National Standards Institute      |
| AEL  | Accessible Emission Limit                  |
| MPE  | Maximum Permissible Exposure               |
| PC   | Physical Connector                         |
| APC  | Angle-polished Connector                   |
| OTDR | Optical Time-Domain Reflectometer          |
| ORL  | Optical Return Loss                        |
| FTTx | Fibre to the x (x can be Curb, Home, etc.) |
| P    | Power                                      |
| W    | Watts                                      |
| OPS  | Optical Pulse Suppressor                   |
| OLTS | Optical Loss Test Set                      |
| IPA  | Isopropyl Alcohol                          |
| WDM  | Wave Division Multiplexing                 |
| OLT  | Optical Line Termination                   |
| ONT  | Optical Network Terminal                   |
| TCP  | Transmission Control Protocol              |
| LOF  | Loss of Frame                              |
| BER  | Bit Error Rate                             |
| QoS  | Quality of Service                         |

### 3 Safety Precautions

There are certain precautions that should be taken when working with optical fibres. Precautions are required to maintain a safe work environment and reduce time lost as a result of accidents. In addition to these precautions, all other safety rules applicable for the installation environment should be followed. Please refer to the IEC 60950 [1] series of recommendations for safety guidelines applicable to telecommunication equipment.

#### 3.1 Cleaving Fibres

When cleaving and stripping optical fibre cables, one should wear proper safety glasses and gloves. Some tools such as strippers and cleavers can be very sharp and can injure the operator. In addition, small glass fragments produced by cutting fibres, cleaving fibres, or during scribing procedures can easily fly into the air. One should be alert to these fragments to avoid injury to the eyes and skin.

#### 3.2 Laser Light Safety

Light from lasers can be harmful to the eye. Laser light used in FTTx networks for transmission of data is invisible. Since one is unable to see it, one cannot tell if the light is causing harm to the eye. In addition, the eye's retina, where the damage occurs, has no pain sensation. Therefore, one should exercise caution while working with lasers or fibres coupled to lasers. Never look into the end of a fibre that may have a laser coupled to it.

The international standard IEC 60825-1 [2] from the International Electrotechnical Commission is applicable regarding laser light safety. Some additional national standards such as ANSI (American National Standards Institute) Z136.x [3] may be adopted by certain countries. ITU-T G.664 [4] also contains some information regarding procedures for preventing injuries to the eyes and skin.

**Note that exposure to small amounts of laser light can lead to permanent eye injury.**

The IEC 60825 classification consists of four classes of lasers based on the accessible emission limit (AEL).

| Class    | Definition  |
|----------|---|
| Class 1  | A class 1 laser is safe under all conditions of normal use. This means the maximum permissible exposure (MPE) cannot be exceeded.   |
| Class 1M | A Class 1M laser is safe for all conditions of use except when it has passed through magnifying optics such as microscopes and telescopes. Class 1M lasers produce large-diameter beams, or beams that are divergent.   |
| Class 2  | A Class 2 laser is safe because the blink reflex will limit the exposure to no more than 0.25 seconds. This classification only applies to visible-light lasers (400–700 nm).   |
| Class 2M | A Class 2M laser is safe because of the blink reflex and also if it is not viewed through optical instruments. As with class 1M, this applies to laser beams with a large diameter or large divergence, for which the amount of light passing through the pupil cannot exceed the limits for class 2.   |
| Class 3R | A Class 3R laser is considered safe if handled carefully, with restricted beam viewing. With a Class 3R laser, the MPE can be exceeded, but with a low risk of injury. Visible continuous lasers in Class 3R are limited to 5 mW. For other wavelengths and for pulsed lasers, other limits apply.  |
| Class 3B | A Class 3B laser is hazardous if the eye is exposed directly, but diffuse reflections such as from paper or other matte surfaces are not harmful. Continuous lasers in the wavelength range from 315 nm to far infrared are limited to 0.5 W. For pulsed lasers between 400 and 700 nm, the limit is 30 mJ. Limits for other wavelengths and ultrashort pulsed lasers also exist. |
| Class 4  | Class 4 lasers include all lasers with beam power greater than class 3B. By definition, a class-4 laser can burn the skin and cause potentially devastating and permanent eye damage due to direct or diffuse beam viewing.   |

Every laser must carry a warning label stating the class of laser as shown in Figure 1. It is the responsibility of the manufacturer to determine the classification of the laser. The manufacturer does so by measuring the wavelength, output power and the pulsing characteristics of the laser.

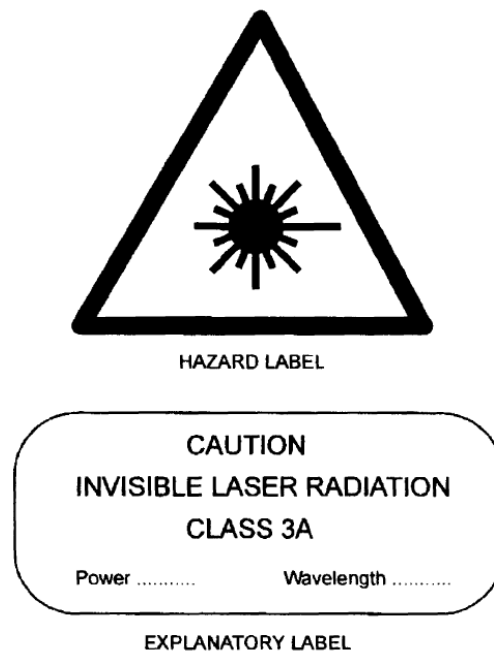

**Figure 1: Laser Light Warning Labels**

### 3.3 Electrical Safety

Before proceeding to test and measure optical fibre systems, one should follow standard electrical safety guidelines and be well trained in electrical wiring and connection practices.

When optical fibre systems run through the same area as electrical wiring or cabinets, use extreme caution when handling tools and ladders. Mistakes can send enough voltage through the body to cause severe injuries. One should remember that electrical fields can exist beyond a cable's insulation if high voltages are present, so wooden ladders should be used to reduce the possibility of exposure to induced voltages. One should also be careful when handling cutters and other tools so as to avoid accidental contact with electrical wires.

## 4 Pre-testing Preparation

Before a test is carried out, some preparation work should be done:

1. Check if the fibre under test is being used to carry live traffic. In other words, distinguish an in-service test from an out-service test.
2. Check the uniformity of connectors, e.g. PC to PC and APC to APC.
3. Clean all connectors.
4. Check if the testing instruments need to be calibrated.
5. Check if the testing equipment needs to be "warmed up".
6. Check the sensitivity and power limit of optical receivers in order to avoid damage to the photodetectors.

## 5 Fibre Test Equipment and Techniques

ITU-T L.40 [5] contains information for the surveillance, testing, and control of optical fibre networks during the preventive maintenance phase and the “after installation before service” or “post fault” maintenance phase. Various types of testing methods are also recommended.

Unlike the L.40, ITU-T L.53 [6] focusses more specifically on the maintenance criteria for access networks as point-to-multipoint networks such as PON require a different testing approach compared to point-to-point networks. The test and measurement equipment is similar to those recommended in ITU-T L.40, and they are described in this section.

Commonly used measurement and test equipment for FTTx networks include the optical power meter, insertion loss tester, visual fault locator, optical time-domain reflectometer (OTDR) and optical return loss (ORL) tester.

### 5.1 Optical Power Meter

The optical power is a measure of the rate at which photons arrive at a photodetector. Thus it is a measure of energy transfer per unit time. In this document, optical power refers to the average power in a specified time slot.

An optical power meter measures the optical power over a selected spectral passband. In an FTTx network, an optical power meter can have the following passbands: 1260 to 1360nm for measurements at 1310nm, 1480 to 1500nm for measurements at 1490nm, and 1540 to 1560nm for measurements at 1550nm. Multiwavelength optical power meters are available on the market today, and they are the most common instruments for measuring optical signal power levels. Usually, the meter outputs are described by dBm, which can be calculated by the following formula:

$$dBm = 10 \log_{10} \frac{P}{1mW}$$

where P is the power in units of Watts (W). Figure 2 depicts a typical handheld optical power meter.



**Figure 2: A Handheld Optical Power Meter  
(Courtesy of EXFO)**

### 5.2 Optical Time-Domain Reflectometer (OTDR)

An optical time-domain reflectometer (OTDR) is one of the most useful instruments to evaluate the transmission characteristics of an installed fibre. In addition to identifying and locating faults or anomalies within a link, this equipment can measure parameters such as fibre attenuation, fibre length, optical connector losses, optical splice losses and light reflectance levels.



**Figure 3: An Example of a Handheld OTDR  
(Courtesy of EXFO)**

### Principle of Operation

An OTDR operates by emitting pulses of light into one end of a fibre and then measuring the reflections generated from the fibre at the same end. The main advantage of an OTDR is that since it measures the time taken for the light to reflect back, the OTDR can provide the distance to various sources of loss in the fibre.

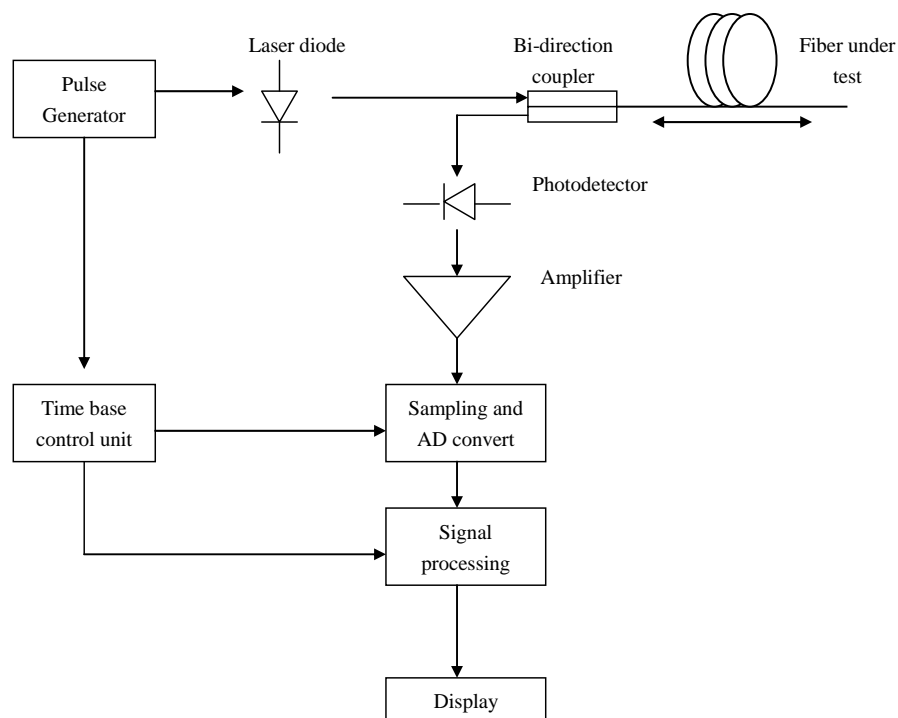

**Figure 4: Major Components of an OTDR**

### Information from OTDR Trace

An operator obtains information on the fibre link from a trace displayed on the OTDR screen (Figure 5). The scale of the vertical axis is logarithmic and represents the reflected signal in decibels. The horizontal axis denotes the distance between the OTDR and the measurement point in the fibre. The slope of the fibre trace is in dB/km and it shows the attenuation coefficient of the fibre.

The connectors and splices along a fibre link produce "events" in the OTDR trace. Although both result in an attenuation loss, they also create reflective peaks in the OTDR trace (Figure 5). The height of those peaks indicates the amount of reflection at the connector or splice. Sometimes, the reflection-related loss of a good fusion splice can be too small to be visible on the OTDR trace.

The resolution of the OTDR is an important specification as one cannot see two events that are closer than is allowed by the pulse width. Generally, longer pulse widths allow an operator to see farther along the fibre link while narrower pulses are used when high resolution is needed, although this limits the length of the fibre the OTDR can measure.

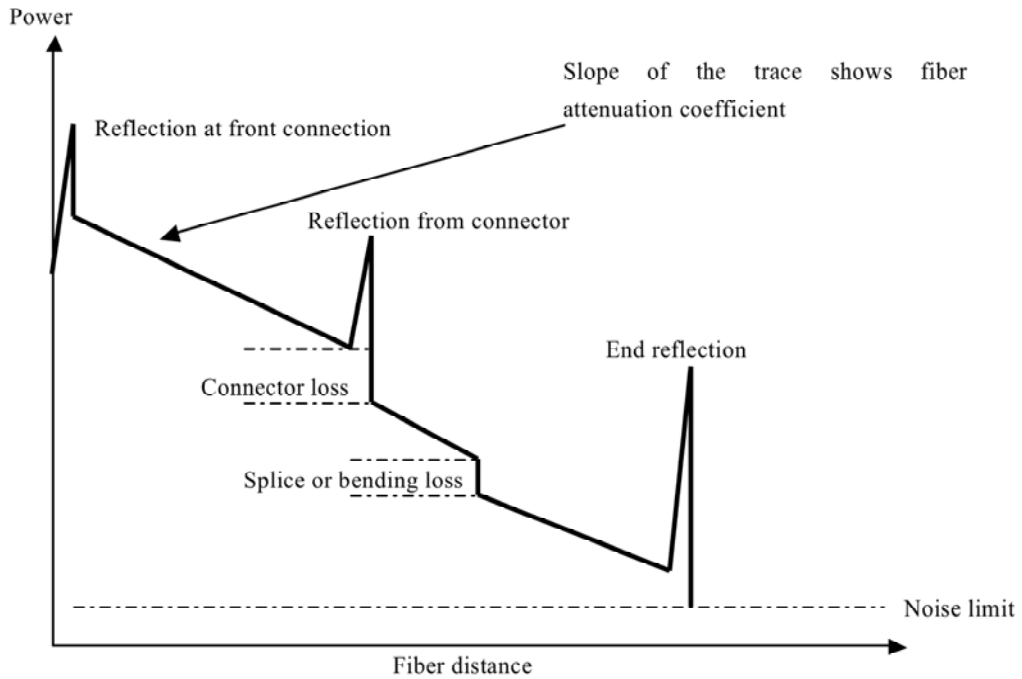

Figure 5: OTDR Trace Information

**Dead Zone**

In an OTDR, the photodiode can be temporarily saturated by a strong optical reflection and the dead zone is defined as the distance over which this occurs. As is evident from Figure 6, the dead zone is classified in two ways.

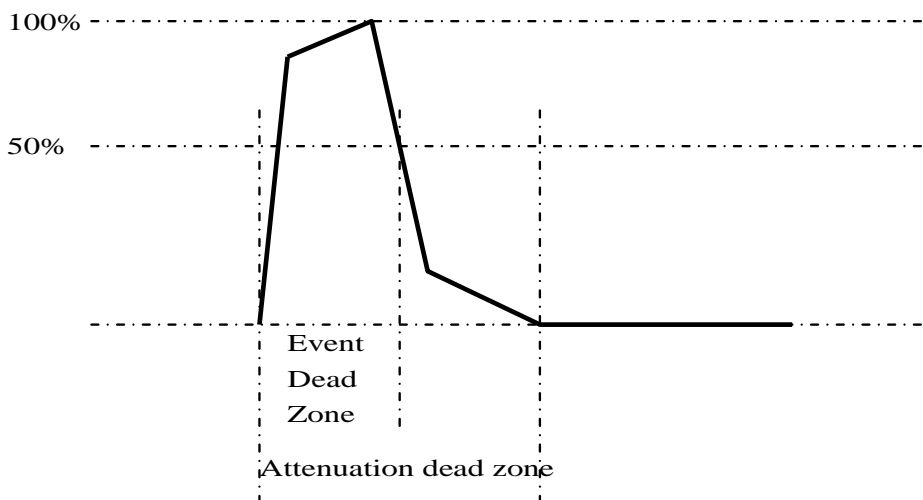

Figure 6: OTDR Dead Zone

The event dead zone is caused by a single reflective event and, in this case, the measured dead zone depends on the time duration of the optical pulse emitted by the OTDR (see Figure 6) and the magnitude of the reflection. In theory, using a shorter pulse length will result in a smaller event dead zone. For a 100ns pulse, the event dead zone is typically 15 m.

The second type is known as the attenuation dead zone and it is defined as the distance over which the photodetector in an OTDR needs to recover following a reflective event before it is again able to detect a reflected signal. Typical attenuation dead zones range from 10 to 25 m.

In order to prevent the dead zone from affecting the measurements, a fibre optic patch cord is typically added to the OTDR measurement port to serve as a “dead zone jumper”. In addition, some OTDR vendors have started to incorporate a special length of fibre called an optical pulse suppressor (OPS) in their equipment. This can reduce the event dead zone to about 1m.

### 5.3 Visual Fault Locator

A visual fault locator is a handheld measurement device that uses a visible laser light source to locate breakpoints, bending or cracks in the fibre. It can also be used for fibre identification.

Usually, the light source in the locator emits a red light beam (at 650nm for example) into a fibre. When the light encounters a fault, the light scatters out of the fibre and is thus visible to the naked eye in the form of a glowing or blinking red light (if the output power of the source is modulated). The output power of the light source in general is 0dBm, so it will be visible even through a fibre jacket. Figure 7 shows a visual fault locator.



**Figure 7: Visual Fault Locator  
(Courtesy of EXFO)**

### 5.4 Optical Return Loss (ORL) Meter

In telecommunications, the return loss is the reflection of signal power resulting from the insertion of a device in a transmission line or optical fibre. Optical return loss can be introduced at optical connectors, fibre endfaces, optical splitter interfaces, and within the fibre itself due to Rayleigh back scattering. If it becomes too high, this reflection can cause optical resonance in the laser source and result in its erratic operation and increased laser noise. In addition, the reflected light can undergo multiple reflections in the transmission link and increase the bit error rate when it enters the receiver.

ORL is usually expressed as a ratio in dB relative to the transmitted signal power. If the power transmitted by the source is  $P_t$  and the power reflected is  $P_r$ , then the return loss in dB is given by:

$$ORL = 10 \log \frac{P_r}{P_t}$$

One can use either an OTDR or an ORL meter to measure this parameter. Figure 8 shows a portable optical return loss test meter.



**Figure 8: Optical Return Loss Meter  
(Courtesy of EXFO)**

### 5.5 Insertion Loss Test Set

The insertion loss is the loss of signal power resulting from the insertion of a device in an optical fibre link. Usually expressed as a ratio in dB relative to the transmitted signal power, it can also be referred to as attenuation loss. The insertion loss (in dB) is given by:

$$10\log_{10} \frac{P_i}{P_t}$$

where,  $P_i$  is the received power at the photodetector and  $P_t$  is the transmitted power of the laser source.

An optical loss test set (OLTS) is used to carry out this testing (Figure 9). This instrument combines a light source and a power meter in a single unit so that only one instrument is required to transmit and detect the optical signal.



**Figure 9: Optical Loss Test Sets  
(Courtesy of EXFO)**

## 5.6 Optical Fibre Identifier

An optical fibre identifier is a measurement device that contains a very sensitive photodetector. When a fibre is bent, some light radiates out of the core due to macrobending loss, and this light can be detected by a fibre identifier, which allows the technician to distinguish a live fibre from a dark one. The fibre identifier can also indicate the presence and direction of a traffic stream without interrupting actual data transmission.



Figure 10: Optical Fibre Identifier  
(Courtesy of EXFO)

## 6 Outside Plant and Optical Fibre Maintenance

### Visual Inspection

A regular scheduled preventative maintenance programme should be established for outdoor installations because they are more susceptible to mechanical and environmental damage. It may be necessary to conduct frequent visual inspection of outside plant networks in order to detect damage or potential damage.

### Cleaning Techniques

Ensuring that a fibre optic connection is clean is one of the most critical requirements for maintaining an error-free communication link. Figure 11 shows a dirty optical connector compared with a clean one.

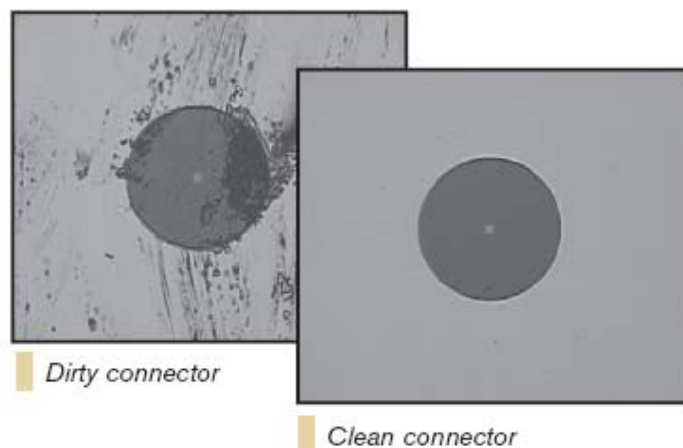

Figure 11: Comparison between a Dirty Connector and a Clean One  
(Courtesy of EXFO)

In a PON system, two types of fibre optic connectors may need regular cleaning depending on the environment in which they are situated.

1. Connectors on a fibre optic patch cable or fibre pigtail of optical splitter
2. Connectors plugged into patch panels or other hardware devices and equipment.

Some popular connector cleaning methods are listed below:

- Dry cleaning: Cleaning without using any solvent.
- Wet cleaning: Cleaning using a solvent. Typically isopropyl alcohol (IPA) is used.
- Non-Abrasive Cleaning: Cleaning without abrasive material touching the fibre optic connector endface. Examples: air dusters or pressured solvent jets used in automated in-situ connector cleaners.
- Abrasive cleaning: Lint-free wipes, reel-based fibre connector cleaners and optic cleaning swabs.

## 7 Device Conformance Certification

The optical distribution network in a PON system includes the feeder cables, distribution fibres, optical connectors, and optical splitters. These devices should be installed and tested according to international standards so that their mechanical and reliability performances can be assured when they are deployed. Table 1 shows some of such standards.

**Table 1: Reliability Standards for Optical Outside Plant Components**

| Standard         | Description  |
|------------------|--|
| GR-13 [7]        | This document contains general, electrical, mechanical and environmental requirements for pedestal terminal closures that house passive optical components used in an outside plant environment. It also includes descriptions of optical measurement techniques such as OTDR.   |
| GR-326 [8]       | This document contains generic performance and reliability assurance requirements for fibre-optic connectors and jumpers. It gives detailed information on test sample preparation, environmental tests, mechanical tests, test facility and equipment requirements, as well as reliability assurance programmes.  |
| GR-1081 [9]      | This document focusses on reliability assurance requirements for field-mountable optical fibre connectors. Most of the tests are covered in GR-326.  |
| GR-1209 [10]     | These two documents describe generic reliability assurance requirements for passive optical components such as couplers, circulators, filters, isolators, and WDMs. Assessment criteria for optical, environmental and mechanical performances of these components are defined. GR-1221 focusses more on reliability assurance programmes as well as reliability and quality criteria. |
| GR-1221 [11]     |  |
| IEC-62134-1 [12] | This recommendation focusses on generic specifications for fibre-optic enclosures. Requirements on classification, documentation, design and workmanship, performance, and identification of enclosures are described. The test procedures are not included in this document but can be found in the IEC 61300 series.   |

|                         |   |
|-------------------------|---|
| IEC-61753-X series [13] | <p>This IEC series contains documents that describe generic requirements for passive fibre-optic products that include connectors, passive optical components, fibre management systems and enclosures. The series comprises multiple parts.</p> <p>Part I (IEC 61753-1) focusses on general information related to performance standards. Various tests and severity conditions are defined. The other parts contain specific performance standards that describe minimum test and measurement severities a product must pass in order to qualify as meeting performance requirements. The following components are included:</p> <ul style="list-style-type: none"> <li>○ Fibre optic connectors (IEC 61753-2-1, IEC 61753-021-2, IEC 61753-021-6 , IEC 61753-022-2)</li> <li>○ Wavelength branching devices (IEC 61753-031-3)</li> <li>○ Attenuators (IEC 61753-051-3 , IEC 61753-053-3)</li> <li>○ Isolators (IEC 61753-061-3, IEC 61753-062-6)</li> <li>○ WDM devices (IEC 61753-081-2 , IEC 61753-082-2, IEC 61753-083-2, IEC 61753-084-2, IEC 61753-085-2, IEC 61753-086-2)</li> <li>○ Circulator (IEC 61753-091-3, IEC 61753-092-6)</li> <li>○ Fibre management system (IEC 61753-101-2, IEC 61753-101-3 )</li> <li>○ Sealed enclosures (IEC 61753-111-7, IEC 61753-111-8, IEC 61753-111-9)</li> <li>○ Mechanical fibre splice (IEC 61753-131-3)</li> </ul> |
|-------------------------|---|

## 8 Network Performance Testing

After the installation of optical fibre links, a network performance test should be implemented, and this usually consists of connectivity testing and traffic performance testing. At this stage, the OLT and the ONT should already be connected to the network and be fully functional.

### Connectivity Testing

Once the FTTx physical networking link is established, the first test that should be conducted is the connectivity test. A simple and low-cost procedure is to use a computer that is connected to the ONT to execute a “Ping” command to connect to a server on the network. There is some commercially available measurement equipment that can perform this test as well.

### Traffic Performance Testing

The connectivity test will only tell whether a network level link is established or not. For a more detailed analysis on the network performance, a traffic performance tester should be used (Figure 12).



**Figure 12: An Example of a Network Performance Tester  
(Courtesy of EXFO)**

The following parameters are usually measured:

1. Throughput: Generally, this testing is carried out using the TCP protocol, and the throughput is dependant on the TCP packet size. After this test, an average bit rate for the network will be reported.
2. Frame loss: Frame loss is an indication that one or more network frames did not get through the networking device (e.g. ONT). When the loss of frame (LOF) error occurs, it typically indicates that the traffic load for this device is too high or some equipment is wrongly configured.
3. Jitter: Jitter is a measure of the time variation in which packets need to be transmitted. If the jitter is high, some applications, such as those that are based on real-time transmission of voice and video, will be adversely affected.
4. Latency: Latency is a measure of time delay experienced by the packets when they are transmitted across the network. If the latency is too high, it will result in a transmission time out.
5. BER (Bit Error Rate): This is one of the most important measures of signal quality. The BER shows how many bits are transmitted wrongly. If the BER is high, many packets have to be re-transmitted, thus slowing down the performance of applications.
6. QoS (Quality of Services): QoS refers to the capability of a telecommunications network to provide differentiated levels of service for different classes of data traffic.

## 9 In-service Testing and Monitoring

### Live Traffic Testing

With the mass development of optical fibre access networks, large quantities of fibres will be installed. At times, because of mislabelling or poor record-keeping, it is not easy to find the exact fibre in a bundle of fibres when the technician needs to test and maintain the network. The optical fibre indicator introduced in section 4.3 provides a quick and easy method to distinguish the live fibres from the dark fibres. It is also able to measure the traffic flow direction.

### Optical Link Testing and Troubleshooting

When a service is activated in a PON system, telephony, data traffic and video data are sent from the OLT to various ONTs at every residential customer location. If any ONT malfunctions and cannot continue to provide services for the customer, this particular branch of the PON becomes inactive and customers who are associated with this branch are disconnected from the network. The solution to this problem usually requires a truck roll, where a technician is dispatched to the customer's premises to troubleshoot and restart the service.

To avoid affecting the remaining branches of the network, the technician should conduct in-service testing and troubleshooting. Executing these tests should not interfere with the upstream and downstream PON wavelengths and thus the ITU-T L.41 [14] standard recommends using the U-band (the central wavelength is 1650 nm) as the maintenance band for an in-service testing of an optical network. Figure 13 shows a typical testing and troubleshooting set-up for a PON system.

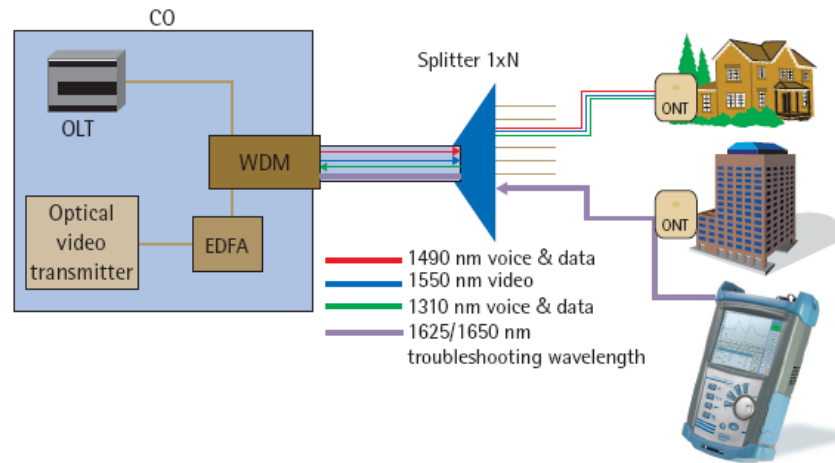

**Figure 13: A Typical Testing and Troubleshooting Set-up for a PON System (Courtesy of EXFO)**

## 10 References

- [1] **IEC 60950.** Safety of Information Technology Equipment - Third Edition. Apr 1, 1999.
- [2] **IEC 60825-1.** Safety of Laser Products - Part 1: Equipment Classification and Requirements - Edition 2.0. Aug 1, 2008.
- [3] **ANSI Z136.x.** Safe Use of Lasers. Oct 26, 2000.
- [4] **ITU-T G.664.** Optical Safety Procedure and Requirements for Optical Transport Systems - Study Group 15. Mar 1, 2006.
- [5] **ITU-T L.40.** Optical Fibre Outside Plant Maintenance Support, Monitoring and Testing System - Study Group 6. Oct 1, 2000.
- [6] **ITU-T L.53.** Optical Fibre Maintenance Criteria for Access Networks - Study Group 6. May 1, 2003.
- [7] **Telcordia GR-13.** Generic Requirements for Pedestal Terminal Closures. Jan 2008.
- [8] **Telcordia GR-326.** Generic Requirements for Single-Mode Optical Connectors and Jumper Assemblies. Sep 1999.
- [9] **Telcordia GR-1081.** Generic Requirements for Field-Mountable Optical Fibre Connectors. Jan 1995.
- [10] **Telcordia GR-1209.** Generic Requirements for Passive Optical Components. Mar 2001.
- [11] **Telcordia GR-1221.** Generic Reliability Assurance Requirements for Passive Optical Components. Jan 1999.
- [12] **IEC 62134-1.** Fibre Optic Interconnecting Devices and Passive Components - Fibre Closures - Part 1: Generic Specification - Edition 2.0. Jun 1, 2009.
- [13] **IEC 61753.** Fibre Optic Interconnecting Devices and Passive Components Performance Standard. 2007.
- [14] **ITU-T L.41.** Maintenance Wavelength on Fibres Carrying Signals - Study Group 6. May 1, 2000.