



**Technical Specification**  
for  
**Radio Pagers**  
**(Public Paging Service)**

**IDA TS RPG**  
**Issue 1, July 2005**

Infocomm Development Authority of Singapore  
Resource Management & Standards  
8 Temasek Boulevard  
#14-00 Suntec Tower Three  
Singapore 038988

© Copyright of IDA, 2005

This document may be downloaded from the IDA website at <http://www.ida.gov.sg> and shall not be distributed without written permission from IDA.

## Contents

<b>Section</b>		<b>Page</b>
<b>1</b>	<b>General Requirements</b>	<b>3</b>
1.1	Scope of Specification	3
1.2	Design of Equipment	3
1.3	Safety and Health	3
<b>2</b>	<b>Technical Requirements</b>	<b>4</b>
2.1	Radio Pagers (Receivers only)	4
2.2	Two-way Radio Pagers	5
<b>3</b>	<b>Testing Conditions and Methods</b>	<b>6</b>
3.1	Standard Test Conditions	6
3.2	Voltages	6
3.3	Transmitter Test Requirements (applicable to 2-way radio pagers only)	6
3.4	Receiver Tests under Standard Test Conditions	6
3.5	Transmitter Tests under Standard Test Conditions (applicable to 2-way radio pagers only)	12
<b>Annex A</b>	<b>Addendum/Corrigendum</b>	<b>14</b>
	Changes to IDA TS 104, TS 105 and TS 113	

<p style="text-align: center;"><b>NOTICE</b></p>
--

<p style="text-align: center;"><b>This Specification is subject to review and revision.</b></p>
---

# 1 General Requirements

## 1.1 Scope of Specification

This Specification defines the conformity assessment requirements for the following types of radio pagers:

- a. POCSAG and FLEX radio pagers operating in the island wide Automatic Paging System (APS)
- b. UHF receivers intended for use in the International Paging Service (IPS)<sup>1</sup>
- c. Two-way radio pagers using POCSAG and Spread Spectrum Code Formats

## 1.2 Design of Equipment

Radio pagers equipment shall be marked with the manufacturer's identification mark and model or type reference. The markings required shall be legible, indelible and readily visible.

## 1.3 Safety and Health

1.3.1 Where appropriate, radio pagers equipment shall comply with the International Commission on Non-Ionising Radiation Protection (ICNIRP) guidelines for limiting exposure to time-varying EMFs in the frequency range up to 300 GHz.

1.3.2 It should be noted that compliance with any radiation safety standard does not by itself confer immunity from legal obligations and requirements imposed by national health or safety authorities.

---

<sup>1</sup> International Paging Service (IPS) enables a subscriber to receive paging calls in a foreign country which has agreement with his home country for this service, on the same pager that the subscriber uses at home.

## 2 Technical Requirements

### 2.1 Radio Pagers (Receivers only)

Pager Type	POCSAG/FLEX Radio Pagers		UHF receivers for IPS
Frequency Range	150 MHz / 280 MHz		929 to 932 MHz (Carrier Frequency 931.9375 MHz)
Channel Spacing	25 kHz		25 kHz
Code Type / Signal Format	POCSAG (ITU-R Paging Code No.1)	FLEX	31/21 POCSAG Code, binary digital NRZ
Modulation	FSK non-return to zero	4 level FSK	FSK non-return to zero
Deviation	Carrier $\pm$ 4.5 kHz	Carrier $\pm$ 4.8 kHz	Positive + 4.5 kHz (Binary 0) Negative - 4.5 kHz (Binary 1)
Signalling Speed	512 bps/1200 bps	6400 bps	1200 bps only
Paging Sensitivity	5 $\mu$ V/m/7 $\mu$ V/m	10 $\mu$ V/m	7 $\mu$ V/m
Adjacent Channel Sensitivity	$\geq$ 55 dB		>55 dB
Spurious and Image Response Rejection	$\geq$ 50 dB		>40 dB
Intermodulation Response Rejection	$\geq$ 50 dB		>50 dB
Frequency Stability	$\pm$ 0.001%		$\pm$ 3 ppm (5°C to 55°C)
Radiated Spurious Emissions	$\leq$ 20 nW		<20 nW
IF Bandwidth	Pager shall be able to accommodate 1000 Hz off-set in the carrier frequency.		–
Other requirements	<p>Pager shall be able to discriminate and not be affected by other signalling code e.g. NEC proprietary and 5-Tone codes.</p> <p>Pager shall not be affected by the prolonged transmission of mark or space frequencies of up to 0.8 second.</p>		Pager shall be capable of being programmed with at least 2 different pager addresses (capcode).

## 2.2 Two-way Radio Pagers

### 2.2.1 Receiver Part

Receiver Specification	
Frequency Range	138 MHz to 174 MHz 278 MHz to 284 MHz
Channel Spacing	25 kHz
Modulation	Binary FSK-NRZ
Deviation	Carrier $\pm$ 4.5 kHz
Code Type	POCSAG (ITU-R Paging Code No.1)
Bit Rate	1200 bps
Paging Sensitivity	7 $\mu$ V/m
Adjacent Channel Selectivity	$\geq$ 55 dB
Spurious and Image Response Rejection	$\geq$ 50 dB
Intermodulation Response Rejection	$\geq$ 50 dB
Frequency Stability	$\pm$ 0.001%
Radiated Spurious Emissions	$\leq$ 20 nW
IF Bandwidth	Pager shall be able to accommodate 1000 Hz off-set in the carrier frequency.
Other Requirements	Pager shall be able to discriminate and not be affected by other signalling code e.g. NEC proprietary and 5-TONE codes. Pager shall not be affected by the prolonged transmission of mark or space frequencies of up to 0.8 second from the base transmitter.

### 2.2.2 Transmitter Part

Transmitter Specification	
Operating Frequency	917.04 MHz ~ 918.96 MHz
Transmission Method	Spread Spectrum Frequency Hopping
Frequency Hopping	5.5 or 16 Hops/second
Hopping Algorithm	Pseudo Random
Channel Spacing	7.5 kHz (Hopping Resolution)
Modulation	DBPSK
Code Type	BCH (63,36) Code
Bit Rate	200 bps
Transmitting Power (ERP)	1W
Phase Noise	- 60 dBc/Hz @ 5 kHz offset - 75 dBc/Hz @ 10 kHz offset
Spurious Emissions	< - 70 dBc
Frequency Stability	$\pm$ 2.5 kHz
Carrier Rejection	> 17 dB

### 3 Testing Conditions and Methods

Suppliers shall demonstrate that the radio pager has been tested and certified to comply with the applicable technical requirements stipulated in section 2 of this Specification. Where applicable to the pager under test, measurement methods and conditions shall be as specified in this section.

#### 3.1 Standard Test Condition

Standard test conditions are to be used for all the tests: temperature from 22°C to 30°C and relative humidity from 65% to 85%.

#### 3.2 Voltages

Voltages shall be as specified by the manufacturer. Pagers shall be expected to perform at nominal voltage down to -10% or just before low voltage alarm is sounded or indicated.

#### 3.3 Transmitter Test Requirements (applicable to 2-way radio pagers only)

##### 3.3.1 Test Fixture for Transmitter with Integral Antenna

3.3.1.1 In the case of transmitter intended for use with an integral antenna, test fixture from the manufacturer shall be used for the relative measurements on the pager under test.

3.3.1.2 The test fixture shall provide a 50 ohms terminal at the working frequencies of the transmitter.

3.3.1.3 The test fixture shall provide means of making external connection to the radio frequency output.

3.3.1.4 The performance characteristics of the test fixture shall be verified by the testing laboratory as follows:

- a. The coupling loss shall not be excessive, that is not greater than 20 dB.
- b. The variation of coupling loss with frequency shall not cause errors exceeding 2 dB in measurements using the test fixture.
- c. The coupling device shall not include any non-linear elements.

#### 3.4 Receiver Tests under Standard Test Condition

##### 3.4.1 Pager Sensitivity

(This test includes the testing of IF Bandwidth to accommodate 1000 Hz "off-set" in the carrier frequency).

Pager sensitivity is the measure of the minimum field strength that will cause the pager to receive from a signal at carrier operating frequency including "off-set" modulated by correct paging address and message, successfully at 5 times out of 5 pages (100% SCR).

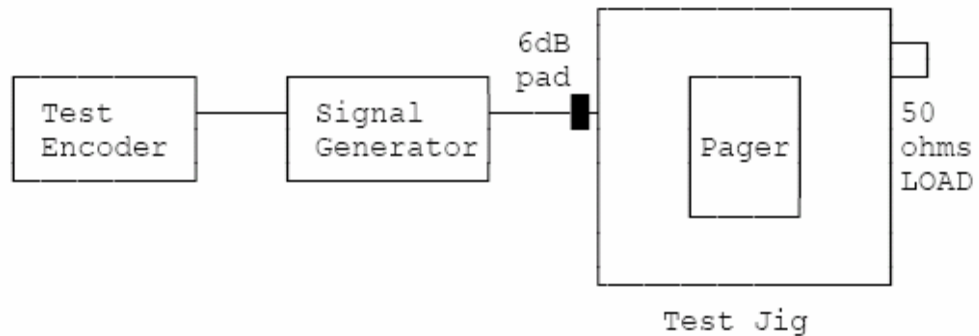
3.4.1.1 Equipment Set-up

Field Strength (FS) in  $\text{dB}\mu\text{V}/\text{m} = \text{Signal Generator Output in } \text{dB}\mu\text{V} - \text{xdB}$

3.4.1.2 Method of measurement

- a. The test shall be conducted in a shielded room.
- b. Signal Generator 1 is set as follows:

Frequency	Fr (carrier frequency)
Modulation	FM EXT.DC
Deviation	$\pm 4.5$ kHz for POCSAG $\pm 4.8$ kHz for FLEX
Amplitude	- 80 dBm

- c. The pager is being paged continuously at the rate of one message every 2 seconds for POCSAG receiver and 5 seconds for FLEX receiver.
- d. The Signal Generator output level is decreased gradually in steps of 1.0 dB until a point where the pager could not receive the page or error message is received. At this point, the Signal Generator output level is increased in steps of 0.1 dB to a point where the pager could receive 5 consecutive pages without errors. This Signal Generator output level is noted.
- e. Repeat the test with the Signal Generator frequency adjusted to  $\pm 1000$  Hz. There should be very little difference between all the output readings. The highest of all the reading shall be adopted.

3.4.1.3 Limits

- a. The minimum Field Strength for POCSAG receiver operating at 512 bps shall be  $5 \mu\text{V}/\text{m}$ ; and operating at 1200 bps shall be  $7 \mu\text{V}/\text{m}$ .
- b. The minimum Field Strength for FLEX receiver operating at 6400 bps shall be  $10 \mu\text{V}/\text{m}$ .
- c. The above Field Strength limits may be adjusted to take account of pagers which are designed to be worn close to the human body (e.g. watch pagers) for added sensitivity. For such cases, the supplier shall state clearly the correction factor and

substantiate it with the necessary technical documents and test reports.

### 3.4.2 Adjacent Channel Selectivity

The Adjacent Channel Selectivity is a measure of the capability of a pager to operate successfully in the presence of a signal in the adjacent channel.

#### 3.4.2.1 Equipment Set-up

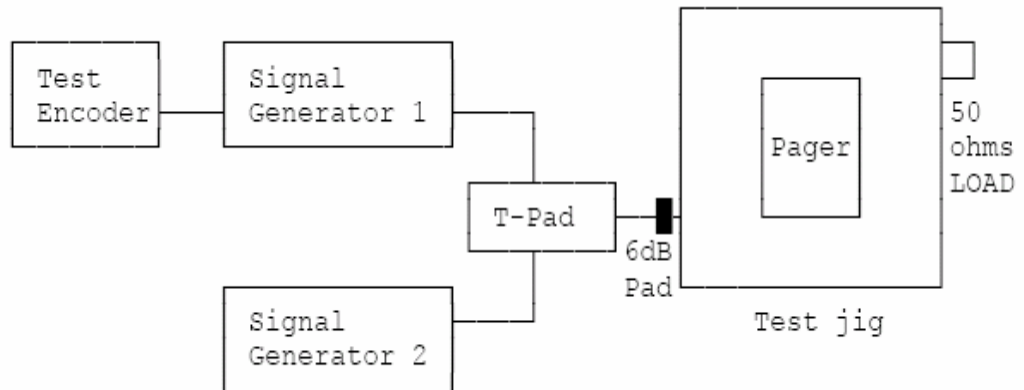

#### 3.4.2.2 Method of measurement

- a. Signal Generators 1 & 2 are set as follows:

Signal Generator 1	Frequency	Fr (carrier frequency)
	Modulation	FM EXT.DC
	Deviation	± 4.5 kHz for POCSAG ± 4.8 kHz for FLEX
	Amplitude	- 80 dBm

Signal Generator 2	Frequency	Fr ± 25 kHz
	Modulation	400 Hz Tone
	Deviation	3 kHz for POCSAG 2.4 kHz for FLEX
	Amplitude	Minimum

- b. With Signal Generator 2 switched OFF, output of Signal Generator 1 is adjusted for the minimum pager sensitivity according to clause 3.4.1. This level is noted, and increased by 3 dB.
- c. With Signal Generator 2 switched ON (unwanted signal), the frequency is set to the upper adjacent channel frequency.
- d. The output level of Signal Generator 2 is increased until the pager does not receive every call successfully.
- e. At this point the output level of Signal Generator 2 is reduced slowly until 5 times out of 5 calls are received without error. The RF level of Signal Generator 2 is noted.
- f. Steps (c) to (e) are repeated for the lower adjacent channel frequency.

- g. The ratio of the RF level of Signal Generator 2 to the RF level of Signal Generator 1 is the Adjacent Channel Selectivity. The lesser of the upper and lower adjacent channel frequency levels shall be used.

### 3.4.2.3 Limits

The limit of the Adjacent Channel Selectivity shall be no less than 55 dB.

### 3.4.3 **Spurious and Image Response Rejection**

Spurious and image response rejection is a measure of the capability of the pager to operate successfully from a wanted signal in the presence of a signal of any other frequency or the image frequency.

3.4.3.1 Equipment set up is similar to Adjacent Channel Selectivity.

#### 3.4.3.2 Method of measurement

- a. Signal Generators 1 & 2 are set as follows:

Signal Generator 1	Frequency	Fr (carrier frequency)
	Modulation	FM EXT.DC
	Deviation	$\pm 4.5$ kHz for POCSAG $\pm 4.8$ kHz for FLEX
	Amplitude	- 80 dBm

Signal Generator 2	Frequency	30 to 1000 MHz
	Modulation	400 Hz Tone
	Deviation	3 kHz for POCSAG 2.4 kHz for FLEX
	Amplitude	0 dBm

- b. With Signal Generator 2 switched OFF, output of Signal Generator 1 is adjusted for the minimum pager sensitivity according to clause 3.4.1. This level is noted, and increased by 3 dB.
- c. With Signal Generator 2 switched ON, RF output is swept from 30 to 1000 MHz (or 2600 MHz for IPS pagers) slowly. At any point where the paging calls of the pager appear to be interrupted, the RF output sweep is stopped. The output level is reduced until the pager is again able to response to pager calls of 5 times out of 5 pages successfully. This level is noted.
- d. Finally the frequency is adjusted to the image frequencies (Operating Frequency  $\pm 2$  IF<sub>1</sub> and Operating Frequency  $\pm 2$  IF<sub>2</sub>), where IF<sub>1</sub> is the 1st IF frequency and IF<sub>2</sub> is the 2nd IF frequency.
- e. The spurious and image response rejection is the difference between the readings obtained from step (c) or (d) [the lower level shall be used] and step (b).

#### 3.4.3.3 Limits

The limit of spurious/ image response rejection shall be no less than 50 dB.

### 3.4.4 Intermodulation Response Rejection

Intermodulation response rejection is a measure of the capability of a pager to inhibit the generation of a successful page response caused by two equal unwanted signals having specific frequency relationship to the nominal operating frequency, one of which is modulated with a normal coded test signal.

#### 3.4.4.1 Equipment Set-up

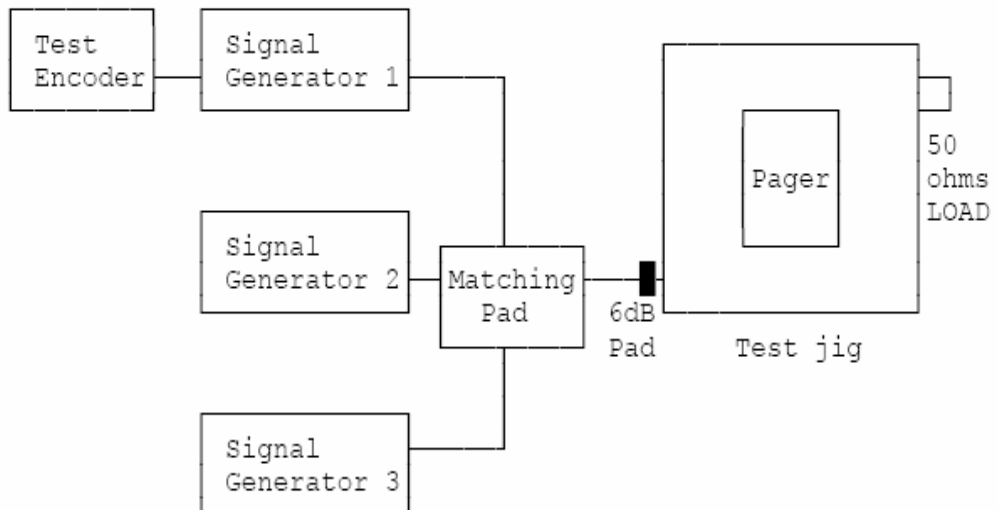

#### 3.4.4.2 Method of measurement

- a. Signal Generators 1, 2 & 3 are set as follows:

Signal Generator 1	Frequency	Fr (carrier frequency)
	Modulation	FM EXT.DC
	Deviation	$\pm 4.5$ kHz for POCSAG $\pm 4.8$ kHz for FLEX
	Amplitude	- 80 dBm

Signal Generator 2	Frequency	Fr $\pm 25$ kHz
	Modulation	Unmodulated

Signal Generator 3	Frequency	Fr $\pm 50$ kHz
	Modulation	400 Hz Tone
	Deviation	3 kHz for POCSAG 2.4 kHz for FLEX

- b. With Signal Generators 2 & 3 switched OFF, output of Signal Generator 1 is adjusted to minimum pager sensitivity according to clause 3.4.1. This level is noted, and increased by 3 dB.
- c. Signal Generator 2 is switched ON and adjusted to the upper adjacent channel frequency without modulation.
- d. Signal Generator 3 is switched ON and adjusted to 2 times the upper adjacent channel frequency.
- e. The RF levels of Signal Generator 2 & 3 are kept equal at minimum and increased simultaneously until the pager does not receive every call successfully.

- f. At this point the levels of both Signal Generators are reduced slowly until 5 times out of 5 calls are received without error.
- g. If necessary the frequencies of the two Signal Generators may be adjusted to obtain better response. This level is noted.
- h. Steps (c) to (f) are repeated for the lower adjacent channel frequency.
- i. The difference in dB between the Signal Generators 2 & 3 and Signal Generator 1 shall be recorded as the intermodulation response rejection.

#### 3.4.4.3 Limits

The limit of the intermodulation response rejection shall be no less than 50 dB.

#### 3.4.5 **Radiated Spurious Emission**

Radiated spurious emission from a pager is any emission radiated by the pager either by way of the integral antenna or radiated directly by the chassis and case of the pager.

##### 3.4.5.1 Method of measurement

- a. The pager shall be placed at a height of one metre from the ground in a room minimum size 5m x 3.2m x 2.6m on a non-conducting support vertically at a distance of 1 metre from the wall.
- b. The quarter-wave antenna attached to a suitable ground plane is placed at the same height 2 metres from the pager.
- c. The antenna is connected to the measuring receiver by a short piece of coaxial cable.
- d. The receiver is tuned, sweeping through the frequency range from 50 MHz to 1000 MHz (or 2000 MHz for IPS pagers).
- e. At each frequency where emission is detected the pager is rotated to get the maximum response. The frequency and received level is noted.
- f. After sweeping through the whole frequency range 50 MHz to 1000 MHz (or 2000 MHz for IPS pagers) and noting all emission, the pager is replaced by an antenna connected to the signal generator.
- g. The frequency and level of the signal generator is adjusted to give the same reading on the measuring receiver as the emission that has been noted previously.
- h. The power radiated by the antenna fed from the signal generator is calculated from the signal generator output and these are the equivalent radiated emission from the pager.

3.4.5.2 Limits

The effective radiated power from any spurious emission in the specified frequency range shall not exceed 20 nW.

**3.5 Transmitter Tests under Standard Test Condition (applicable to 2-way radio pagers only)**

**3.5.1 Operating Frequency Range**

The occupied frequency range of the transmitter spectrum shall fall within the allocated frequency band. This is also valid at maximum frequency errors from the centre frequency of the band.

**3.5.2 Transmitting Power (ERP)**

Effective radiated power (ERP) refers to the product of the power supplied to the antenna and the maximum antenna gain relative to a half-wavelength dipole antenna. The permissible radiated power shall be the peak power, i.e. the power over the active part of a frame slot.

3.5.2.1 Method of measurement

- a. The test shall be conducted in a shielded room.
- b. The transmitter shall be modulated with a pseudo-random 200 bps bit stream.
- c. The transmitter power shall be measured using a spectrum analyzer with narrow frequency span and appropriate attenuation. Peak hold detection shall be used to centre the transmitting frequency of the test sample.

3.5.2.2 Limits

The effective radiated power at maximum output power (using the antenna gain recommended by the pager manufacturer) shall not exceed 1W.

**3.5.3 Frequency Stability**

Frequency stability is the ability of the transmitter to maintain the assigned frequency within the specified tolerance.

3.5.3.1 Method of measurement

The method of measurement is described in clause 3.5.2.1.

3.5.3.2 Limits

The RF carrier frequency shall not depart from the reference frequency by +/- 2.5 kHz.

**3.5.4 Spurious Emissions (Radiated)**

Spurious emissions are emissions on a frequency or frequencies outside the necessary bandwidth which result from the modulation process and harmonics.

#### 3.5.4.1 Method of measurement

- a. The test shall be conducted in a shielded room.
- b. The spectrum of the transmitter shall be determined by a spectrum analyzer of specific resolution bandwidths in the average power mode.
- c. The transmitter shall be modulated with a pseudo-random 200 bps bit stream and with frequency hopping feature disabled.
- d. Emission of any spurious components shall be detected by a spectrum analyzer which is swept over a frequency range from the lowest frequency either internally generated or used in the device (local oscillator, intermediate or carrier frequency) up to the 5th harmonic of the highest frequency generated or used.

#### 3.5.4.2 Limits

The spurious emissions shall not exceed the limit of - 70 dBc (where dBc is the dB relative to the transmitter mean output power)

**Annex A: Corrigendum / Addendum**

<b>Changes to IDA TS 104, TS 105 &amp; TS 113</b>			
<b>Page</b>	<b>TS Ref.</b>	<b>Items Changed</b>	<b>Effective Date</b>
—	—	<p>This Specification supersedes the following IDA Type Approval Specifications:</p> <ul style="list-style-type: none"><li>a. IDA TS 104 Issue 1 Rev 4</li><li>b. IDA TS 105 Issue 1 Rev 3</li><li>c. IDA TS 113 Issue 1 Rev 2</li></ul>	21 Jul 05
—	—	<p>Title of Specification has been renamed as “Technical Specification for Radio Pagers (Public Paging Service)” (IDA TS RPG Issue 1).</p> <p>Changes are mainly editorial in nature. The essential technical requirements for conformity assessment remain unchanged.</p>	21 Jul 05