

**SCHEDULE 4B**  
**SUBMARINE CABLE CONNECTION SERVICE**

## CONTENTS

1. SCOPE	1
2. CATEGORIES OF CABLE SYSTEMS	2
3. ORDERING AND PROVISIONING PROCEDURE	3
4. LINK AND CAPACITY ACTIVATION REQUEST	5
5. DEACTIVATION	6
6. STANDARD TERMS AND CONDITIONS	7
7. ACCESS AND APPROVALS REQUIRED	8
8. OPERATIONS AND MAINTENANCE	8
9. TERM	12
10. SUSPENSION	13
11. TERMINATION	13
ANNEX 4B.1	
ANNEX 4B.2	
ANNEX 4B.3	
ANNEX 4B.4	
ANNEX 4B.5	

## SCHEDULE 4B

### SUBMARINE CABLE CONNECTION SERVICE

#### 1. SCOPE

1.1 This Schedule sets out the terms and conditions under which SingTel will provide the Requesting Licensee with the Connection Service and on which the Requesting Licensee may access or use the Connection Service.

1.2 The Connection Service is a service provided by SingTel to the Requesting Licensee for implementing, establishing and maintaining a connection between:

(a) the Requesting Licensee's Co-Location Equipment located at the Co-Location Space at the Submarine Cable Landing Station, or such other location as contemplated in the process set out in clauses 1.2 to 1.6 of Schedule 8; and

(b) a Cable System,

for the sole purpose of accessing cable capacity on the Cable System in accordance with clause 1.3.

1.3 SingTel shall provide the Connection Service to the Requesting Licensee solely for the purposes of enabling the Requesting Licensee to:

(a) access its own cable capacity on the Cable System; and/or

(b) access the cable capacity owned by any Third Party, on the Cable System for the purpose of:

(i) providing a backhaul service to that Third Party who is duly licensed by the Authority; and/or

(ii) enabling that Third Party to transit traffic between the Cable System being connected under this Schedule 4B (**A-end Cable System**) and another cable system (**B-end cable system**). For the avoidance of doubt, if SingTel is the landing party of the B-end cable system, the Requesting Licensee may request the Connection Service from SingTel in respect of that B-end Cable System pursuant to this Schedule 4B.

- 1.4 The provision of Co-Location Space and physical access thereto at a Submarine Cable Landing Station must be acquired by a Requesting Licensee in accordance with Schedule 8D or using the process contemplated in clauses 1.2 to 1.6 of Schedule 8.
- 1.5 This Schedule only applies to Requesting Licensees who are FBOs.
- 1.6 (a) The timeframes in this Schedule relating to the provision of the Connection Service, capacity activation and link activation are subject to delays caused by events outside SingTel's reasonable control, in which case SingTel may extend these timeframes for a period equal to the period of such delays.
- (b) For the avoidance of doubt, a failure to meet these timeframes caused by events outside SingTel's reasonable control does not constitute a breach of this Schedule or this RIO Agreement.
- 1.7 (a) If SingTel fails to meet any timeframes in this Schedule relating to the provision of the Connection Service, capacity activation and link activation and the failure to meet the timeframe is solely caused by SingTel, SingTel will provide a remedy to the Requesting Licensee.
- (b) Such remedy will be in the form of a credit to the Requesting Licensee of the recurring Charges payable for the delayed services over a period equal to the period of the delay.
- (c) The Requesting Licensee acknowledges that this remedy is a genuine pre-estimate of the Requesting Licensee's loss and will be the sole and exclusive remedy available to the Requesting Licensee for such failure and shall be SingTel's sole and exclusive liability to the Requesting Licensee for such failure.

## **2. CATEGORIES OF CABLE SYSTEMS**

- 2.1 (a) The terms and conditions of the Connection Service vary according to the Cable System. For this purpose, Cable Systems are divided into Group A Cable Systems and Group B Cable Systems, as described in Annex 4B.5.
- (b) The method of access to Group A Cable Systems is shown in Annex 4B.1.
- (c) The method of access to Group B Cable Systems is via a Cross Connect System, as shown in Annex 4B.2.

## **2.2 New Cable Systems**

- (a) Where a new Cable System, which is not specified in clause 2.1 and Annex 4B.5 (**New Cable System**), lands at any Submarine Cable Landing Station, Sing Tel shall submit to the Authority for approval any necessary amendments to the RIO (including but not limited to Schedules 4B and 8D) to incorporate the New Cable System into the RIO, within 14 Calendar Days from the Ready for Service date of the New Cable System. Upon approval by the Authority, SingTel shall amend the RIO and this RIO Agreement accordingly.
- (b) The Requesting Licensee may request the Connection Service in respect of the New Cable System where the Requesting Licensee has obtained or is in the process of obtaining Co-Location Space under Schedule 8D or Co-location Space contemplated in clauses 1.2 to 1.6 of Schedule 8 and where the New Cable System lands at the Submarine Cable Landing Station at which the Co-location Space is obtained.

## **3. ORDERING AND PROVISIONING PROCEDURE**

- 3.1 SingTel shall offer to provide the Connection Service to a Requesting Licensee on terms and conditions that are no less favourable than the terms and conditions on which it provides comparable services to itself or its affiliates.
- 3.2 SingTel shall process and respond to all requests under this Schedule 4B on a 'first come, first served' basis in the timeframe specified in this clause 3 in respect of the relevant request. SingTel shall process a maximum of five (5) Requests for Connection Service per day from all Requesting Licensees under this Schedule 4B (whether those requests are made under clause 4 or 5). Any subsequent requests received by SingTel in excess of this maximum amount shall overflow to the next Business Day, in which case SingTel shall advise the Requesting Licensee of the queue number of the relevant request.
- 3.3 Where a Request for Connection Service is to access the cable capacity of any Third Party on the Cable System, as contemplated by clause 1.3(b):
  - (a) SingTel will not be obliged to activate the capacity unless and until the Requesting Licensee provides to SingTel a copy of a letter of authorisation issued by the Third Party authorising the Requesting Licensee to access the relevant Third Party's capacity;
  - (b) the Requesting Licensee must inform SingTel in writing within forty eight (48) hours if such authorisation is varied or revoked; and

(c) if the Requesting Licensee's authorisation is revoked, SingTel's obligation to supply the Connection Service will cease immediately in accordance with clause 11.1.

3.4 The requirements in clause 3.3 are in addition to and are not substitutes for the requirement for the Requesting Licensee to submit a Request for Connection Service in respect of the Connection Service sought. For the avoidance of doubt, the Requesting Licensee shall submit separate Requests for Connection Service for each of the A-end Cable System and, if SingTel is the landing party in respect of the B-end cable system, the B-end cable system.

3.5 SingTel may reject a Request for Connection Service if:

(a) the Request for Connection Service is in respect of a Cable System other than as specified in clause 2.1;

(b) the Request for Connection Service is not in the prescribed form specified in this Schedule 4B;

(c) where the Connection Service is sought in relation to accessing the cable capacity of any Third Party, the Request for Connection Service is not accompanied by the Third Party's letter of authorisation specified in clause 3.3;

(d) the Request for Connection Service does not contain all the required information;

(e) the Requesting Licensee:

(i) does not hold a licence to the necessary Co-Location Space under Schedule 8D;

(ii) does not hold a licence to such other Co-location Space as contemplated in the process set out in clauses 1.2 to 1.6 of Schedule 8; or

(iii) in either case, the Requesting Licensee has not submitted a request to SingTel to obtain Co-Location Space under the applicable schedules, as the case may be; or

(f) the Requesting Licensee submits a request under this Schedule 4B which seeks to activate capacity where the relevant link has not been activated or sought to have been activated.

3.6 For all types of Cable Systems:

(a) the Requesting Licensee shall be responsible for all terminations at its own equipment and for providing the associated cabling and connectors between the Requesting

Licensee's Equipment and SingTel's distribution frame in order to facilitate the physical termination of the link to SingTel's distribution frame;

- (b) SingTel shall advise the Requesting Licensee of the type of connectors and the length of the associated cables referred to in paragraph (a) for the related capacity that is to be provisioned; and
- (c) SingTel shall provide the distribution frame in connection with the routing of the Requesting Licensee's circuits to the Cable System and shall perform the physical termination of the Requesting Licensee's equipment or cabling to SingTel's distribution frame.

3.7 For Group B Cable Systems, SingTel shall provide the Cross Connection that is necessary only for routing the Requesting Licensee's circuits to the Cable System during the effective period of this Schedule.

3.8 The Requesting Licensee shall be responsible for the relevant Charges specified in Schedule 9 for the Connection Services provided in this Schedule 4B.

#### 4. **LINK AND CAPACITY ACTIVATION REQUEST**

4.1 The Requesting Licensee shall submit its link activation and/or capacity activation requests in the form of a Link Capacity Activation Request Form (**LCAR Form**) provided in Annex 4B.3, with the relevant boxes checked. The LCAR Form must be provided to SingTel no less than thirty (30) Business Days prior to the requested date of activation of the:

- (a) link (**Link Activation Date**);
- (b) capacity (**Capacity Activation Date**); or
- (c) both link and capacity (**Link Capacity Activation Date**).

For the avoidance of doubt, in respect of Group B Cable Systems, a Requesting Licensee is permitted to request capacity activation together with activation of its associated link within one single request.

4.2 SingTel shall process the LCAR Form and advise the Requesting Licensee, within five (5) Business Days of its receipt or any other period as may be agreed between the parties, with one of the following responses:

- (a) that SingTel is able to activate the requested link and/or capacity, as the case may be, by the date specified in the LCAR Form;
- (b) that SingTel is able to activate the requested link and/or capacity, as the case may be, but will not be able to do so by the date specified in the LCAR Form as procurement is required; or
- (c) the LCAR form is rejected for a reason specified in clause 3.5.

4.3 SingTel shall be entitled to levy and receive the processing charge specified in Schedule 9 for each LCAR Form that is rejected in accordance with this clause.

4.4 If procurement is required in order to meet the request pursuant to clause 4.1, SingTel shall seek confirmation of the requested link and/or capacity from the Requesting Licensee. Upon confirmation, SingTel shall complete the required procurement no later than the time at which it would reasonably complete such procurement for itself.

4.5 A minimum term of twelve (12) months shall apply to:

- (a) each link activated in accordance with this clause 4, measured from the earlier of the Link Activation Date or Link-Capacity Activation Date (if applicable); or
- (b) each link activated prior to the commencement of this Schedule 4B, measured from the date of commencement of that link under the relevant agreement,

**(Link Term); and**

- (c) capacity activated on a Group B Cable System in accordance with an LCAR Form under this clause 4, measured from the earlier of the Capacity Activation Date or Link-Capacity Activation Date (if applicable); or
- (d) capacity activated on a Group B Cable System prior to the commencement of this Schedule 4B, measured from the date of commencement of that capacity under the relevant agreement.

**(Capacity Term).**

## **5. DEACTIVATION**

5.1 If the Requesting Licensee wishes to deactivate a link and/or capacity under this Schedule 4B, it must submit a request for link deactivation and/or capacity deactivation in the form

of a Link Capacity Deactivation Request Form (**LCDR Form**) provided in Annex 4B.4. The Lcdr Form must be provided to SingTel no less than ten (10) Business Days prior to the intended Link Capacity Deactivation Date (**LCDD**). For the avoidance of doubt, in respect of Group B Cable Systems, a Requesting Licensee is permitted to request capacity deactivation together with deactivation of its associated link within one single request.

5.2 SingTel shall process the Lcdr Form and advise the Requesting Licensee of its acceptance or otherwise within five (5) Business Days of its receipt. SingTel may reject the Lcdr Form if:

- (i) the request for link and/or capacity deactivation is not in the prescribed form specified in this clause;
- (ii) the request for link and/or capacity deactivation does not contain all the required information;
- (iii) the request for link and/or capacity deactivation is less than ten (10) Business Days prior to the LCDD.

5.3 SingTel shall be entitled to levy and receive the processing charge specified in Schedule 9 for each Lcdr Form that is rejected in accordance with this clause.

5.4 Where the Lcdr Form is applicable to a link during the Link Term the Requesting Licensee shall remain liable for the recurring charges specified in Schedule 9 from the date of such deactivation (or partial deactivation if such is the extent of the Lcdr Form) for the remainder of that Link Term.

5.5 In respect of Group B Cable Systems, where the Lcdr Form is applicable to capacity during the Capacity Term, the Requesting Licensee shall be liable to SingTel for the recurring charges specified in Schedule 9 from the date of such deactivation (or partial deactivation if such is the extent of the Lcdr Form) for the remainder of that Capacity Term.

## 6. **STANDARD TERMS AND CONDITIONS**

6.1 The Requesting Licensee will:

- (a) promptly comply with all reasonable written notices or instructions given by SingTel in respect of the installation, use or operation of the Connection Service;

- (b) not use, attempt to use, nor permit any other person to use, the Connection Service in breach of any laws or regulations whatsoever, and will comply with all relevant directions and orders issued by the Authority from time to time; and
- (c) provide and install the associated cables between its own equipment and SingTel's Distribution Frame and terminate the associated cables to its own equipment.

6.2 SingTel will:

- (a) operate and maintain the Connection Service in accordance with international industry standards;
- (b) operate and maintain the Connection Service on no less favourable terms and conditions in which it operates and maintains comparable services provided to itself and its affiliates;
- (c) address any fault affecting the Connection Service promptly and in accordance with international industry standards and on no less favourable terms and conditions in which it addresses any fault affecting comparable services provided to itself and its affiliates; and
- (d) exercise the reasonable skill and care of a competent telecommunications operator in performing its obligations under this Schedule and ensure that the Connection Service it provides to the Requesting Licensee is of the quality comparable to what it provides to itself and to its affiliates.

## **7. ACCESS AND APPROVALS REQUIRED**

- 7.1 The Parties shall comply with clause 16.5 of the main body of this RIO Agreement in relation to the obtaining of all licences, permits, consents, waivers, authorisations and intellectual property or other rights required for the provision of the Connection Service.

## **8. OPERATIONS AND MAINTENANCE**

### **8.1 Notification**

Each Party shall as soon as practicable provide notification to the other Party in case of any fault or service interruption which is identified by the first-mentioned Party and to notify the other Party when the service is normalised.

## **8.2 Planned Maintenance**

Each Party shall provide not less than five (5) Business Days notice of any planned maintenance, which may affect the other Party's system. Each Party shall use its reasonable endeavours to minimize disruption to the other Party.

## **8.3 Fault Resolution**

- (a) If a fault or service interruption is identified to be caused by the Requesting Licensee, the point of contact is:

Requesting Licensee O&M Contacts:

Tel (office hour):

Tel (after office hour):

Fax:

Requesting Licensee Station Address:

- (b) If a fault or service interruption is identified to be caused by SingTel, the point of contact is:

SingTel's O&M Contacts:

Tel (office hr):

Tel (after office hr):

Fax:

SingTel's Cable Station Address :

#### 8.4 Type Of Faults

Faults reported may be classified as follows:

- (i) Service affecting fault(s); and
- (ii) Non-service affecting fault(s).

Service affecting fault(s) may cause service interruption due to a system or physical link failure. Excessive data errors encountered on the links causing high data loss may also be classified as service affecting fault(s). Non-service affecting fault(s) are those that do not adversely affect data carried on the links.

#### 8.5 Target Response Times

The target response time for attendance to an alarm or reported fault will depend on the time of its occurrence as contained in Table 1 below. "Office Hours" is defined as 8am to 5pm for Mondays to Fridays (except Public Holidays). The whole of Saturday, Sunday and any Public Holiday and the hours outside the Office Hours are referred to as "After Office Hours".

Fault Type	Response Time	
	During Office Hours	After Office Hours
Service Affecting	within one (1) hour of receipt of notification	within two (2) hours of receipt of notification
Non-Service Affecting	within two (2) hours of receipt of notification	within next Business Day of receipt of notification

**Table 1 - Target Response Time**

## 8.6 Fault Escalation

- (a) Where a fault persists and the Parties agree that progress of the remedy is not satisfactory, the fault may be escalated according to the fault escalation timescales and escalation reporting levels as outlined in sub-clauses 8.7 and 8.8 herein respectively.
- (b) The Parties shall immediately inform the first level of escalation within the respective Party's organisation at the same time when the Party which detected the fault notifies the fault reporting point of the Party for action.

## 8.7 Fault Escalation Timescales

The Parties shall use the following timescales as guidelines for the fault escalation process. The timescales shall be used in deciding whether the restoration of a fault is being progressing satisfactorily. If the escalation time has expired and both Parties are satisfied with the progress of the fault restoration, no immediate escalation is necessary.

Fault Type	Maximum Time For Escalation (Commencing after the Response Time)	
	First Level	Second Level
Service Affecting	Immediate	two (2) hours
Non-Service Affecting	Immediate	eight (8) hours

**Table 2 – Fault Escalation Timescales**

## 8.8 Escalation Reporting Levels

All requests for escalation shall be notified through each Party's fault reporting point. The reporting levels are :

<b>Operator</b> <b>Escalation Level</b>	<b>SingTel</b>	<b>Requesting Licensee</b>
First	Connection Service Engineer	to be advised by Requesting Licensee
Second	Connection Service Manager	to be advised by Requesting Licensee

**Table 3 - Escalation Reporting Levels**

**8.9 Persistent or Repeated Faults**

Persistent or repeated faults or issues which cannot be resolved satisfactorily through the normal channels of the Parties shall be escalated to the Second Level to expedite the fault clearance process.

**8.10 Escalation Problems**

The Parties shall notify their respective and appropriate officers stated in Table 3 above for problems encountered in the implementation or execution of the fault escalation procedures.

**9. TERM**

9.1 The Connection Service shall commence on the date SingTel notifies the Requesting Licensee of its acceptance of the Request for Connection Service in accordance with clause 4 and continue until the earlier of the following events:

- (a) the expiry or termination of the licence for Co-Location Space in respect of the Co-Location Equipment at the relevant Submarine Cable Landing Station in accordance with Schedule 8D of this RIO Agreement;
- (b) upon expiry or termination of any licence in respect of other space acquired by the Requesting Licensee using the process contemplated in clauses 1.2 to 1.6 of Schedule 8 (as the case may be); or

- (c) no Co-Location Space is obtained by the Requesting Licensee within 90 Calendar Days of first application for a Request for Connection Service in respect of that Co-Location Space by the Requesting Licensee.

## 10. **SUSPENSION**

- 10.1 Subject to clauses 12.1 and 12.2 of the main body of this RIO Agreement, SingTel may suspend the Connection Service, capacity or link at any time until further notice to the Requesting Licensee if the Connection Service, capacity, link or licence in respect of the Submarine Cable Landing Station causes or is likely to cause physical or technical harm to any telecommunications network, system or services (whether of SingTel or any other person) including but not limited to causing damage, interfering with or causing deterioration in the operation of SingTel's Network.
- 10.2 Without limiting the exclusions or limitations of liability in this RIO Agreement, SingTel shall not be liable to the Requesting Licensee for any Loss resulting from, or in connection with, suspension of the Connection Service under this clause 10.

## 11. **TERMINATION**

- 11.1 Subject to clauses 13.1 and 13.2 of the main body of this RIO Agreement, SingTel may immediately terminate the Connection Service or any capacity or link provided in respect of a Cable System if:
  - (a) the Requesting Licensee is no longer an FBO;
  - (b) in SingTel's reasonable opinion, the Requesting Licensee is using the Connection Service in contravention of an applicable law, licence, code, regulation or direction and SingTel has the necessary confirmation from the relevant Governmental Agencies that the Requesting Licensee is in contravention of the applicable law, licence, code, regulation or direction;
  - (c) in SingTel's reasonable opinion, the Requesting Licensee is using the Connection Service in a manner which places a Third Party in contravention of an applicable law, licence, code, regulation or direction and SingTel has the necessary confirmation from the relevant Governmental Agencies that the Third Party is in contravention of the applicable law, licence, code, regulation or direction;
  - (d) the Connection Service is used by the Requesting Licensee for a purpose other than the purposes specified in clause 1.3;

(e) the use of the Connection Service causes or is likely to cause physical or technical harm to any telecommunications network, system or services (whether of SingTel or any other person) including but not limited to causing damage, interfering with or causing deterioration in the operation of SingTel's Network; or

(f) the letter of authorisation referred to in clause 3.3(a) is revoked.

11.2 Either Party (**Terminating Party**) may terminate the Connection Service if the other Party is in breach of this Schedule and such breach remains unremedied for a period of five (5) Business Days after receiving notice from the Terminating Party to do so.

11.3 Upon expiry or termination of the Connection Service:

(a) the Requesting Licensee must discontinue the use of the Connection Service; and

(b) SingTel shall disconnect the Requesting Licensee's connectors terminated at SingTel's distribution frame; and

(c) the Requesting Licensee must disconnect the connectors terminated at its distribution frame and remove the associated cabling between the Requesting Licensee's equipment and SingTel's distribution frame,

within ten (10) Business Days after the expiry or from the date of termination, whichever is the earlier.

11.4 If the Requesting Licensee fails to disconnect and remove the associated cabling and connectors between the Requesting Licensee's equipment and SingTel's distribution frame under clause 11.3, SingTel shall remove the Requesting Licensee's associated cabling and connectors. The Requesting Licensee shall pay to SingTel all reasonable costs associated with the work undertaken by SingTel including the disposal of the Requesting Licensee's associated cabling and connectors. In such event, the Requesting Licensee shall have no claim whatsoever against SingTel.

11.5 If, prior to the expiry of any applicable Link Term and/or Capacity Term:

(a) SingTel lawfully terminates the Connection Service, capacity or link in accordance with the terms of this Schedule; or

(b) the Connection Service is terminated or expires in accordance with clause 9.1,

the Requesting Licensee shall be liable only for the recurring charges for the relevant links and capacity for the remaining period of the applicable Link Term and/or Capacity Term.

11.6 This clause 11 survives termination of this Schedule 4B or this RIO Agreement.

**ANNEX 4B.1**

**Connection Service diagram for Group A Submarine Cable Systems**

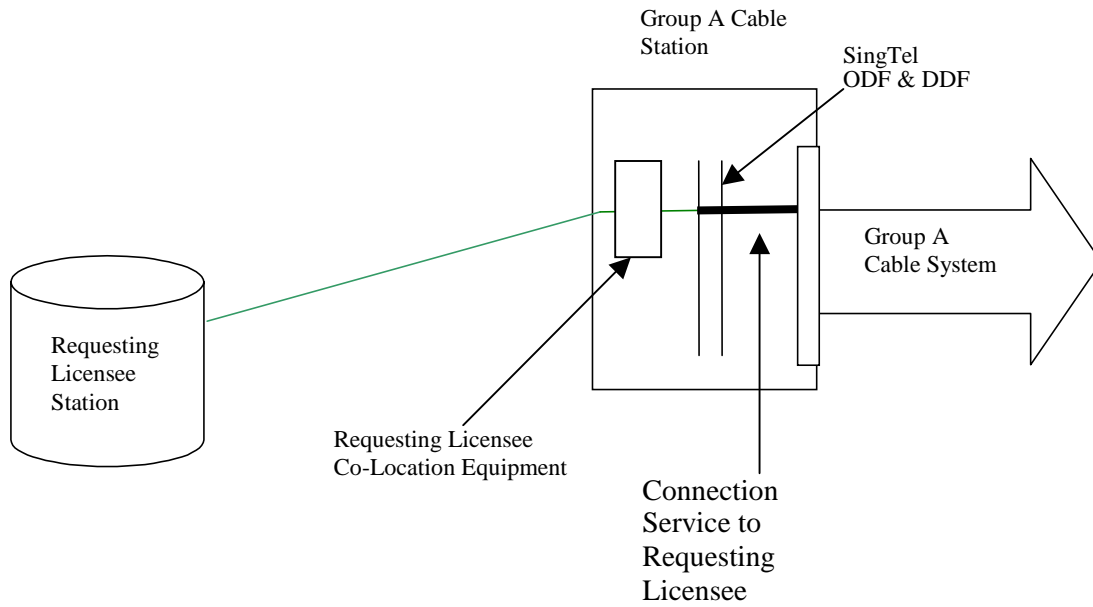

ANNEX 4B.2

Connection Service diagram for Group B Submarine Cable Systems

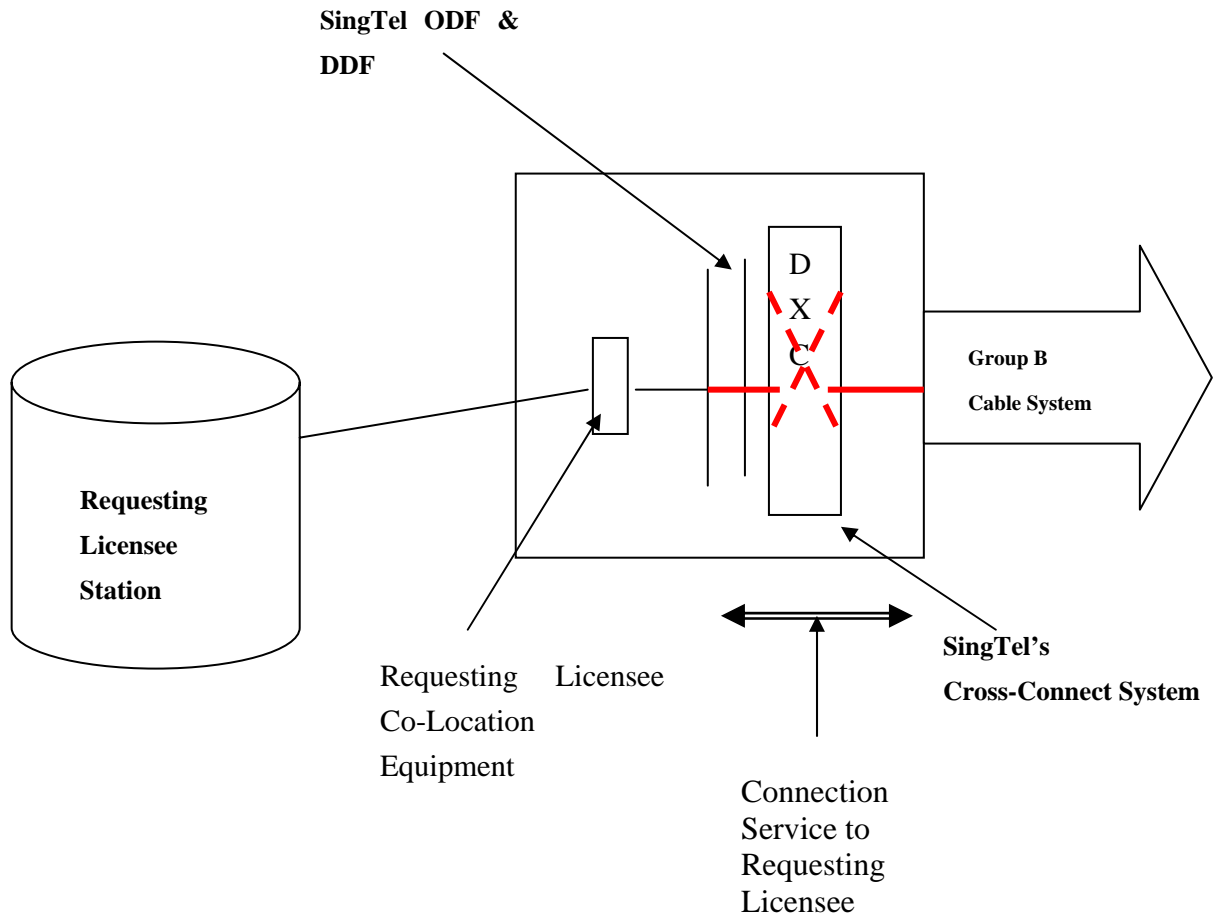



**SingTel**

**Link-Capacity Activation Request**

Date:

To: Manager, Network Integration and Interconnect

Fax: 65-6848 4113

1.	Requesting Licensee:																	
	<table style="width: 100%; border: none;"> <tr> <td style="width: 70%;">Name:</td> <td style="width: 30%; text-align: right;"><b>Please tick relevant box:</b></td> </tr> <tr> <td>Signature:</td> <td style="text-align: right;"><input type="checkbox"/> <b>Link Activation Only</b></td> </tr> <tr> <td>Telephone:</td> <td style="text-align: right;"><input type="checkbox"/> <b>Capacity Activation Only</b></td> </tr> <tr> <td>Facsimile:</td> <td style="text-align: right;"><input type="checkbox"/> <b>Link and Capacity Activation</b></td> </tr> <tr> <td>Company Stamp:</td> <td></td> </tr> </table>	Name:	<b>Please tick relevant box:</b>	Signature:	<input type="checkbox"/> <b>Link Activation Only</b>	Telephone:	<input type="checkbox"/> <b>Capacity Activation Only</b>	Facsimile:	<input type="checkbox"/> <b>Link and Capacity Activation</b>	Company Stamp:								
Name:	<b>Please tick relevant box:</b>																	
Signature:	<input type="checkbox"/> <b>Link Activation Only</b>																	
Telephone:	<input type="checkbox"/> <b>Capacity Activation Only</b>																	
Facsimile:	<input type="checkbox"/> <b>Link and Capacity Activation</b>																	
Company Stamp:																		
2.	Submarine Cable System:																	
	<b>Link Particulars applicable to both Group A &amp; B Cable Systems</b>																	
3a.	Link Connection Bit Rate: <b>Electrical Co-axial cable / Optical fibre *</b>																	
3b.	Capacity Designation:																	
3c.	Cable System Circuit Allocation:																	
3d.	Requesting Licensee's ODF/DDF Port Assignment: <b>Service link (SVR)/ Protection link (PRT)*</b>																	
3e.	<table style="width: 100%; border: none;"> <tr> <td style="width: 50%;">Fibre/Co-axial Patch Cord Assignment: (SRV/PRT)</td> <td style="width: 50%; text-align: center;"> <table style="width: 100%; border: none;"> <tr> <td style="border-bottom: 1px solid black; width: 30%;"><u>RL's ID</u></td> <td style="border-bottom: 1px solid black; width: 30%;"><u>Patch No.</u></td> <td style="border-bottom: 1px solid black; width: 30%;"></td> </tr> <tr> <td style="text-align: center;">/</td> <td style="text-align: center;">/</td> <td style="text-align: center;">/A –Tx(Svr)</td> </tr> <tr> <td style="text-align: center;">/</td> <td style="text-align: center;">/</td> <td style="text-align: center;">/B – Rx(Svr)</td> </tr> <tr> <td style="text-align: center;">/</td> <td style="text-align: center;">/</td> <td style="text-align: center;">/C – Tx(Prt) *</td> </tr> <tr> <td style="text-align: center;">/</td> <td style="text-align: center;">/</td> <td style="text-align: center;">/D – Rx (Prt) *</td> </tr> </table> </td> </tr> </table>	Fibre/Co-axial Patch Cord Assignment: (SRV/PRT)	<table style="width: 100%; border: none;"> <tr> <td style="border-bottom: 1px solid black; width: 30%;"><u>RL's ID</u></td> <td style="border-bottom: 1px solid black; width: 30%;"><u>Patch No.</u></td> <td style="border-bottom: 1px solid black; width: 30%;"></td> </tr> <tr> <td style="text-align: center;">/</td> <td style="text-align: center;">/</td> <td style="text-align: center;">/A –Tx(Svr)</td> </tr> <tr> <td style="text-align: center;">/</td> <td style="text-align: center;">/</td> <td style="text-align: center;">/B – Rx(Svr)</td> </tr> <tr> <td style="text-align: center;">/</td> <td style="text-align: center;">/</td> <td style="text-align: center;">/C – Tx(Prt) *</td> </tr> <tr> <td style="text-align: center;">/</td> <td style="text-align: center;">/</td> <td style="text-align: center;">/D – Rx (Prt) *</td> </tr> </table>	<u>RL's ID</u>	<u>Patch No.</u>		/	/	/A –Tx(Svr)	/	/	/B – Rx(Svr)	/	/	/C – Tx(Prt) *	/	/	/D – Rx (Prt) *
Fibre/Co-axial Patch Cord Assignment: (SRV/PRT)	<table style="width: 100%; border: none;"> <tr> <td style="border-bottom: 1px solid black; width: 30%;"><u>RL's ID</u></td> <td style="border-bottom: 1px solid black; width: 30%;"><u>Patch No.</u></td> <td style="border-bottom: 1px solid black; width: 30%;"></td> </tr> <tr> <td style="text-align: center;">/</td> <td style="text-align: center;">/</td> <td style="text-align: center;">/A –Tx(Svr)</td> </tr> <tr> <td style="text-align: center;">/</td> <td style="text-align: center;">/</td> <td style="text-align: center;">/B – Rx(Svr)</td> </tr> <tr> <td style="text-align: center;">/</td> <td style="text-align: center;">/</td> <td style="text-align: center;">/C – Tx(Prt) *</td> </tr> <tr> <td style="text-align: center;">/</td> <td style="text-align: center;">/</td> <td style="text-align: center;">/D – Rx (Prt) *</td> </tr> </table>	<u>RL's ID</u>	<u>Patch No.</u>		/	/	/A –Tx(Svr)	/	/	/B – Rx(Svr)	/	/	/C – Tx(Prt) *	/	/	/D – Rx (Prt) *		
<u>RL's ID</u>	<u>Patch No.</u>																	
/	/	/A –Tx(Svr)																
/	/	/B – Rx(Svr)																
/	/	/C – Tx(Prt) *																
/	/	/D – Rx (Prt) *																
3f.	Intended Link Activation Date:																	
	<b>Capacity Particulars applicable to Group B Cable Systems only</b>																	
4a.	Circuit Designation:																	
4b.	Cable System's Circuit Allocation:																	
4c.	Intended Capacity Activation Date:																	
5.	<table style="width: 100%; border: none;"> <tr> <td style="width: 60%;">Contacts for Test/Maintenance:</td> <td style="width: 40%;">Name:</td> </tr> <tr> <td></td> <td>Tel:</td> </tr> <tr> <td></td> <td>Fax:</td> </tr> </table>	Contacts for Test/Maintenance:	Name:		Tel:		Fax:											
Contacts for Test/Maintenance:	Name:																	
	Tel:																	
	Fax:																	

\* Delete where not applicable – For the avoidance of doubt, the Service link does not include the Protection link.



**Link-Capacity Deactivation Request**

Date:  
 To: Manager, Network Integration and Interconnect  
 Fax: 65-6848 4113

1.	Requesting Licensee:											
	Name:	<b>Please tick relevant box:</b>										
	Signature:	<input type="checkbox"/> <b>Link Deactivation Only</b>										
	Telephone:	<input type="checkbox"/> <b>Capacity Deactivation Only</b>										
	Facsimile:	<input type="checkbox"/> <b>Link and Capacity Deactivation</b>										
	Company Stamp:											
2.	Submarine Cable System:											
	<b>Link Particulars applicable to both Group A &amp; B Cable Systems</b>											
3a.	Link Connection Bit Rate:	<b>Electrical Co-axial cable / Optical fibre *</b>										
3b.	Capacity Designation:											
3c.	Cable System Circuit Allocation:											
3d.	Requesting Licensee's ODF/DDF Port Assignment:	<b>Service link (SVR)/ Protection link (PRT)*</b>										
3e.	Fibre/Co-axial Patch Cord Assignment: (SRV/PRT)	<table style="width: 100%; border-collapse: collapse;"> <thead> <tr> <th style="text-align: left; border-bottom: 1px solid black;"><u>RL's ID</u></th> <th style="text-align: left; border-bottom: 1px solid black;"><u>Patch No.</u></th> </tr> </thead> <tbody> <tr> <td style="border-bottom: 1px solid black;">/</td> <td style="border-bottom: 1px solid black;">/A -Tx(Svr)</td> </tr> <tr> <td style="border-bottom: 1px solid black;">/</td> <td style="border-bottom: 1px solid black;">/B - Rx(Svr)</td> </tr> <tr> <td style="border-bottom: 1px solid black;">/</td> <td style="border-bottom: 1px solid black;">/C - Tx(Prt) *</td> </tr> <tr> <td style="border-bottom: 1px solid black;">/</td> <td style="border-bottom: 1px solid black;">/D - Rx (Prt) *</td> </tr> </tbody> </table>	<u>RL's ID</u>	<u>Patch No.</u>	/	/A -Tx(Svr)	/	/B - Rx(Svr)	/	/C - Tx(Prt) *	/	/D - Rx (Prt) *
<u>RL's ID</u>	<u>Patch No.</u>											
/	/A -Tx(Svr)											
/	/B - Rx(Svr)											
/	/C - Tx(Prt) *											
/	/D - Rx (Prt) *											
3f.	Intended Link Deactivation Date:											
	<b>Capacity Particulars applicable to Group B Cable Systems only</b>											
4a.	Circuit Designation:											
4b.	Cable System's Circuit Allocation:											
4c.	Intended Capacity Deactivation Date:											
5.	Contacts for Test/Maintenance:	Name: Tel: Fax:										

\* Delete where not applicable – For the avoidance of doubt, the Service link does not include the Protection link.

## **ANNEX 4B.5**

### **CABLE SYSTEMS**

(a) Group A Cable Systems:

- (i) APCN2 Cable System – for Co-Location Equipment located at the Katong Submarine Cable Landing Station;
- (ii) C2C Cable System - for Co-Location Equipment located at the Changi Submarine Cable Landing Station.
- (iii) i2i Cable System - for Co-Location Equipment located at the Tuas Submarine Cable Landing Station;
- (iv) TIS Cable System - for Co-Location Equipment located at the Changi Submarine Cable Landing Station.

(b) Group B Cable Systems:

- (i) APCN Cable System - for Co-Location Equipment located at the Changi Submarine Cable Landing Station;
- (ii) SEA-ME-WE 3 Cable System - for Co-Location Equipment located at the Tuas Submarine Cable Landing Station.